

IMPORTANT — BEFORE OPERATING ENGINE

- READ OWNER'S MANUAL AND THE INSTRUCTIONS FOR THE EQUIPMENT (APPARATUS) THIS GENERATOR WILL POWER
- Failure to follow instructions may result in serious injury or death.



GASOLINE GENERATOR

OWNER'S MANUAL



GOSS Industries Inc.

6226 Danville Road, Mississauga, Ontario L5T-2H7

www.p3power.ca

CONTENTS

1.SAFETY INFORMATION.....	2
2.CONTROL FUNCTION.....	4
3.PRE-OPERATION CHECK.....	5
4.OPERATION.....	6
5.PERIODIC MAINTENANCE.....	9
6.TROUBLE SHOOTING.....	12
7.STORAGE.....	14
8.SPECIFICATIONS.....	15
9.WIRING DIAGRAM.....	17

! WARNING

PLEASE READ AND UNDERSTAND THIS MANUAL COMPLETELY BEFORE OPERATING THE MATCHINE.

1. SAFETY INFORMATION

1) EXHAUST FUMES ARE POISONOUS

- Never operate the engine in a closed area or it may cause unconsciousness and death within a short time. Operate the engine in a well ventilated area.

2) FUEL IS HIGHLY FLAMMABLE AND POISONOUS

- Always turn off the engine when refueling
- Never refuel while smoking or in the vicinity of an open flame.
- Take care not to spill any fuel on the engine or muffler when refueling.
- If you swallow any fuel, inhale fuel vapor, or allow any to get in your eyes, see your doctor immediately. If any fuel spills on your skin or clothing, immediately wash with soap and water and change your clothes.
- When operating or transporting the machine, be sure it is kept upright. If it tilts, fuel may leak from the carburetor or fuel tank.

3) ENGINE AND MUFFLER MAY BE HOT

- Place the machine in a place where pedestrians or children are not likely to touch the machine.
- Avoid placing any flammable materials near the exhaust outlet during operation.
- Keep the machine at least 1 m (3 ft) from buildings or other equipment, or the engine may overheat.
- Avoid operating the engine with a dust cover.

4) ELECTRIC SHOCK PREVENTION

- Never operate the engine in rain or snow.
- Never touch the machine with wet hands or electrical shock will occur.
- Be sure to ground (earth) the generator.

NOTE:

Use ground (earth) lead of sufficient current capacity.

Ground (earth) Lead

Diameter: 0.12mm (0.005 in)/ampere

EX: 10 Ampere --1.2mm (0.055 in)

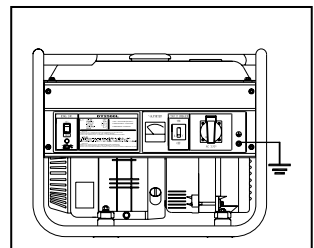

5) CONNECTION NOTES

- Avoid connecting the generator to commercial power outlet.

- Avoid connecting the generator in parallel with any other generator.
- Do not connect the generator to your homes main electrical supply/panel

6) BATTERY

- No smoking while handling the battery.
- The battery emits flammable hydrogen gas, which can explode if exposed to electric arcing or open flame.
- Keep the area well-ventilated and keep open flames/sparks away when handling the battery

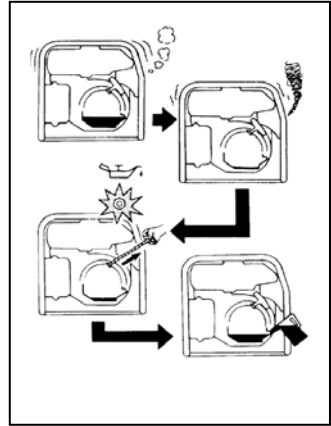

2. CONTROL FUNCTION

1) OIL WARNING SYSTEM

When the oil level falls below the lower level, the engine stops automatically. Unless you refill with oil, the engine will not start again.

2) ENGINE SWITCH

The engine switch controls the ignition system.

① "ON"(run)

Ignition circuit is switched on.

The engine can be started.

② "OFF"(stop)

Ignition circuit is switched off.

The engine will not run.

③ "START"

Starting circuit is switched on.

The starter motor starts.

GS1000W, GS3000W, GS4500W, GS5500W, GS6500W

GSE4500W, GSE5000W, 6SE6000W

3) AC SWITCH (N.F.B.)

The AC switch turns off automatically when the load exceeds the generator rated output.

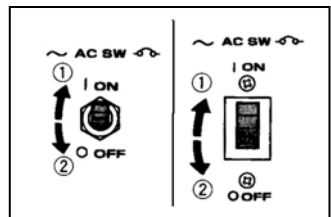
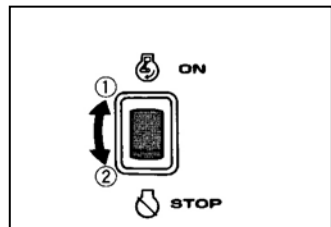
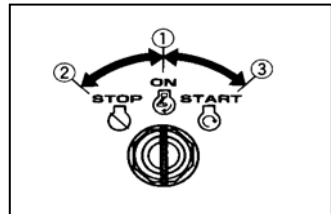

CAUTION:

Reduce the load to within specified generator rated output if the AC switch (N.F.B.) turn off.

DESCRIPTION

- | | | | |
|---------------------|------------------------------|-------------------------|-------------------------|
| (1) Fuel tank | (2) Fuel tank cap | (3) Fuel cock | (4) Air filter cover |
| (5) Spark plug | (6) Muffler | (7) Choke lever | (8) AC socket |
| (9) Engine switch | (10) Ground (earth) terminal | (11) Oil filler cap | (12) Oil drain plug |
| (13) Recoil starter | (14) Fuel level gauge | (15) DC circuit breaker | (16) AC switch (N.F.B.) |
| (17) Voltmeter | (18) DC socket | (19) Pilot lamp | |

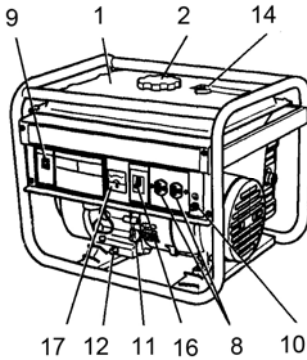

GS1000W

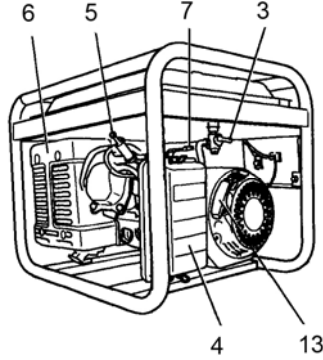

GS3000W

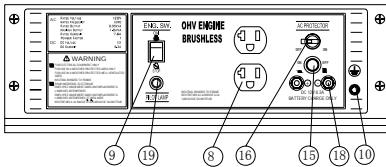

GS4500W, GS5500W

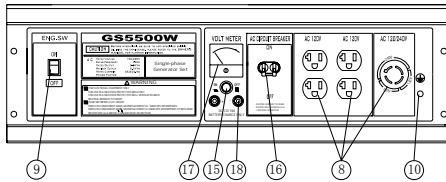

GS6500W

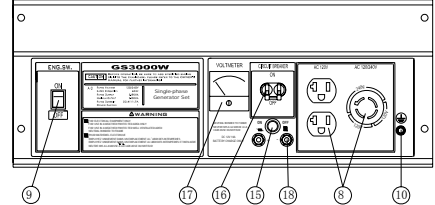
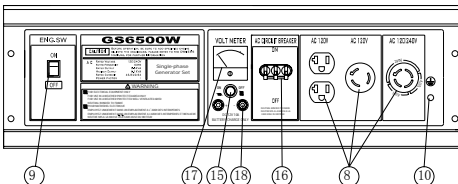

GSE5000W

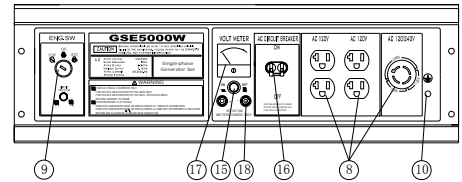

GSE6000W

3. PRE-OPERATION CHECK

NOTE: _____

Pre-operation checks should be made each time the generator is used.

1) CHECK ENGINE FUEL

- Check fuel level at fuel level gauge.
- If fuel level is low, refill with unleaded automotive gasoline.
- Be sure to use the fuel filter screen on the fuel filter neck.
- Recommended fuel: Unleaded gasoline.
- Fuel tank capacity:

Model

GS1000W

GS3000W

GS4500, GS5500W, GS6500W, GSE5000W, GSE6000W

Full

4.8 liters

12 liters

22 liters

WARNING: _____

- Do not refill tank while engine is running or hot.
- Close fuel cock before refueling with fuel.
- Be careful not to admit dust, dirt, water or other foreign objects into fuel.
- Wipe off spilt fuel thoroughly before starting engine.
- Keep open flames away.
- "F" Full, "E" Empty.

2) CHECK ENGINE OIL

Before checking or refilling oil, be sure the generator is put on a stable and level surface with engine stopped.

- Remove oil filler cap and check the engine oil level.
- If oil level is below the lower level line, refill with suitable oil to upper level line. Do not screw in the oil filler cap when checking oil level.
- Change oil if contaminated.
- Oil capacity

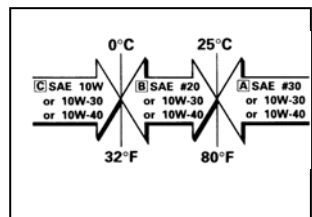
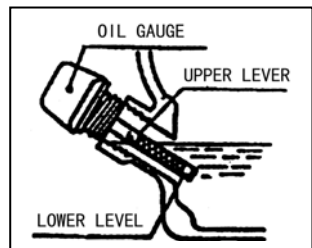
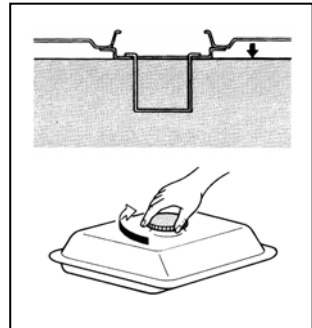
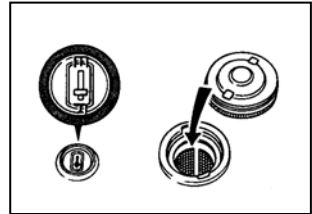

Model

GS1000W

GS3000W

GS4500W, GS5500W, GS6500W, GSE5000W, GSE6000W

Full

0.4 liters

0.6 liters

1.1 liters

- Recommended engine oil:
API Service "SE" or "SF", if not available, "SD".

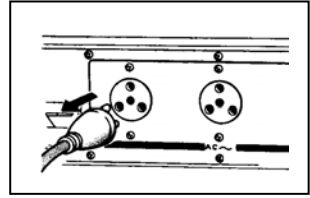

3) GROUND (Earth)

Make sure to ground (earth) the generator.

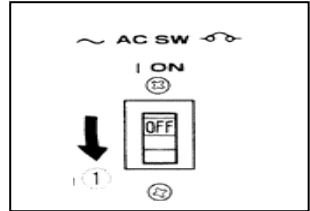

4. OPERATION

NOTE:

The generator has been shipped without engine oil. Fill with oil or it will not start.

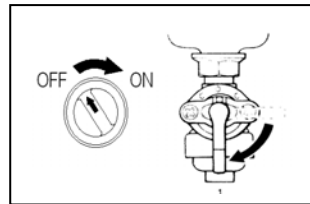

1) STARTING THE ENGINE

NOTE:

- Before starting the engine, do not connect the electric apparatus.
- Turn the AC switch (N.F.B.) to "OFF".

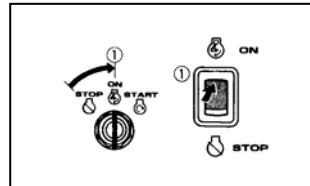

1. Turn the fuel cock lever to "ON".
2. Turn the engine switch to "ON"
3. Turn the choke lever to the " | 🐦 | " position. Not necessary if the engine is warm.
4. Pull the starter handle slowly until resistance is felt. This is the "Compression" point. Return the handle to its original position and pull swiftly. Do not fully pull out the rope. After starting, allow the starter handle to return to its original position while still holding the handle.
5. Warm up the engine.
6. Turn the choke lever back to the operating position.
7. Warm up the engine without a load for a few minutes.

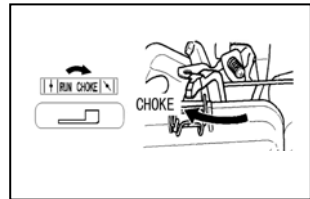

2) USING ELECTRIC POWER

1. AC APPLICATION (SINGLE VOLTAGE TYPE)

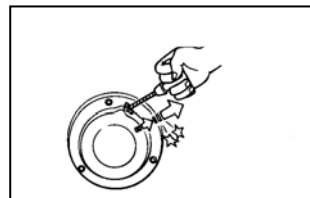

- (a) Check the voltmeter or pilot lamp for proper voltage.
- (b) Turn off the switch(es) of the electrical appliance(s) before connecting to the generator.
- (c) Insert the plug(s) of the electrical appliance(s) into the receptacle.
- (d) Turn the AC switch to The "ON" position and turn on the electric apparatus.

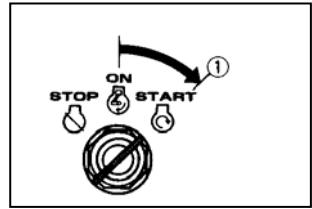

CAUTION: _____

- Be sure the electric apparatus is turned off before plugging in.
- Be sure the total load is within generator rated output.
- Be sure the socket load current is within socket rated current.
- To take out power from TWIST LOCK receptacle, insert the plug into receptacle and turn clockwise to lock it.

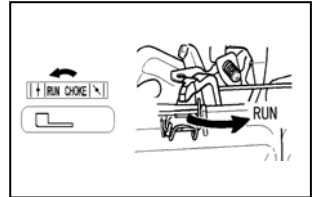

2. AC APPLICATION (DUAL VOLTAGE TYPE)

- (a) Select the voltage using the AC OUTPUT SELECT SWITCH in accordance with the electrical appliance.
- (b) Operate in the same way as step (a) through step (d) of single voltage type.

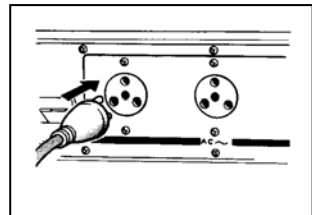

NOTE: _____

Voltmeter always indicates the lower voltage whichever the AC OUTPUT SELECT SWITCH is set.

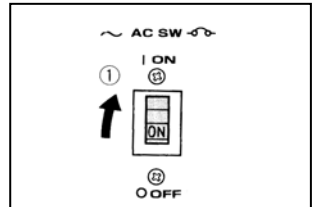

3. DC APPLICATION (option)

This usage is applicable to 12V battery charging only.

- (a) Charging instruction for battery
 - Disconnect the leads for the battery.
 - Make the battery fluid filler cap loose fully.
 - Fill distilled water to the upper limit, if the battery fluid is low level.
 - Measure the specific gravity for the battery fluid by using the hydrometer, and calculate the charging time in according with the table shown on right side.
 - The specific gravity for the fully charged battery shall be within 1.26 to 1.28. It is recommended to confirm every an hour.

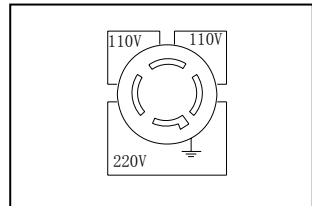

- (b) Connect between the DC output socket and the battery terminals using the charging leads. The leads shall be connected making sure of the (+) and (-) polarity.
- (c) The DC circuit protector is to be set to "ON" after confirming the connection, if the protector is in "OFF" position.

3) STOPPING THE ENGINE

1. Turn off the power switch of the electric apparatus or unplug the cord from receptacle of the generator. Turn the AC switch to "OFF".
2. Turn the engine switch to "OFF".
3. Turn the fuel cock lever to "OFF".

4) BATTERY

(for electric starting system)

1. REPLENISHING THE BATTERY FLUID

- Check the fluid level. The level should be between the upper and lower level marks.
- Add only distilled water if necessary.

2. BATTERY STORE

Remove the battery and charge it. Store it in a dry place and recharge it once a month. Do not store the battery in an excessively warm or cold place.

3. RECOMMENDED BATTERY

- Recommended battery: 12V/26A • h

NOTE: _____

- Clamp the red wire to the positive (+) terminal and the black wire to the negative (-) terminal of the battery. Do not reverse these positions.
- Be sure the battery is installed on the battery mount tray securely

NOTE: _____

In order to increase the longevity of your generator it is advantageous to maintain a minimum load of approximately one third the rated output.

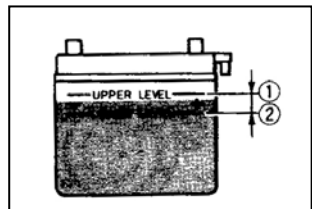
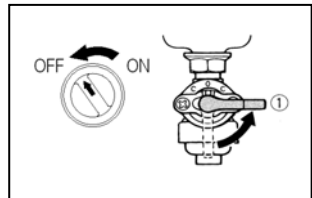
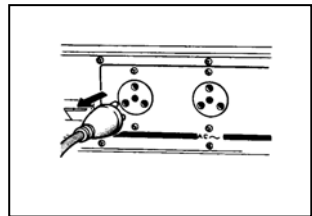
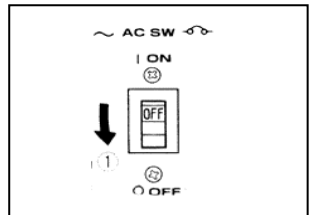
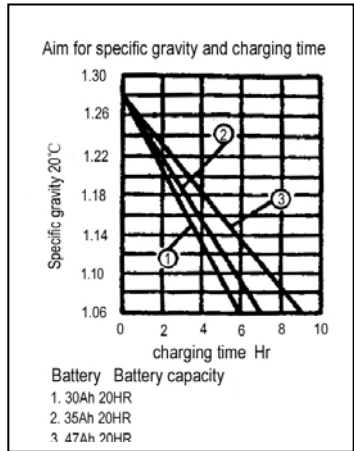

5.PERIODIC MAINTENANCE

1) MAINTENANCE CHART

Regular maintenance is most important for the best performance and safe operation.

Item	Remarks	Pre-operation check (daily)	Initial 1 months or 20 Hr	Every 3 months or 50Hr	Every 6 months or 100Hr	Every 12 months or 300Hr
Spark Plug	Check condition adjust gap and clean. Replace if necessary.			●		
Engine Oil	Check oil level	●				
	Replace		●		●	
Air Filter	Clean. Replace if necessary.			●		
Fuel Filter	Clean fuel cock filter. Replace if necessary				●	
Valve Clearance	Check and adjust when engine is cold.					●
Fuel Line	Check fuel hose for crack or damage. Replace if necessary.	●				
Exhaust System	Check for leakage. Retighten or replace gasket if necessary	●				
	Check muffler screen. Clean / replace if necessary.				●	
Carburetor	Check choke operation	●				
Cooling system	Check fan damage.					●
Starting system	Check recoil starter operation.	●				
Decarbon i-zation	More frequently if necessary.					●
Fittings / Fasteners	Check all fittings and fasteners correct if necessary.				●	

2) ENGINE OIL REPLACEMENT

1. Place the machine on a level surface and warm up the engine for several minutes. Then stop the engine.
2. Remove the oil filler cap
3. Place an oil pan under the engine. Remove the oil drain plug so that the oil can be completely drained.
4. Check the oil drain plug, gasket, oil filler cap and O-ring. If damaged replace.
5. Reinstall the oil drain plug.
6. Add engine oil to the upper level.
 - Recommended engine oil:
API Service "SE" or "SF", if not available, "SD". (see page 6)

CAUTION:

Be sure no foreign material enters the crankcase.

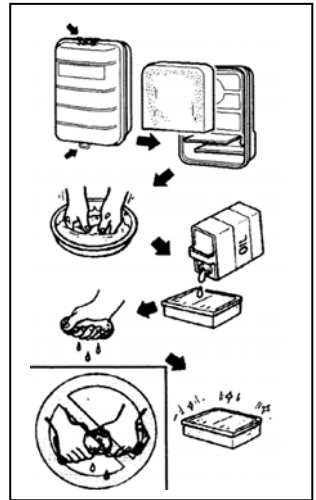
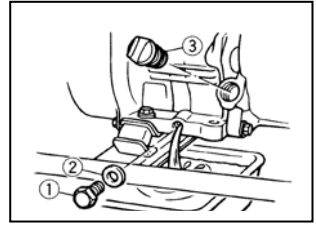

3) AIR FILTER

Maintaining an air cleaner in proper condition is very important. Dirt induced through improperly installed, improperly serviced, or inadequate elements damages and wears out engines. Keep the element always clean.

1. Take out the air cleaner, clean it well in kerosene and dry it.
2. After wetting the element by clean engine oil, squeeze it tight by hand.
3. Lastly, put the element in the case and install it securely.

CAUTION:

The engine should never run without the element; excessive piston and/or cylinder wear may result.

4) CLEANING AND ADJUSTING SPARK PLUG

Standard electrode color: Tan Color
Standard Spark Plug: BPR4ES (NGK)
Spark Plug Gap: 0.7-0.8 mm (0.028-0.031 in)

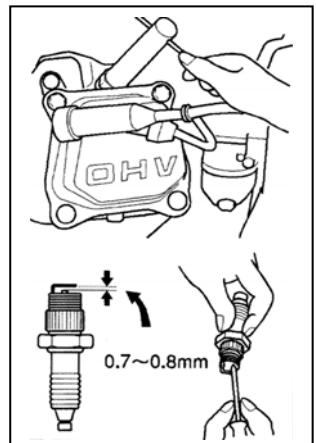

5) FUEL COCK

1. Stop the engine.
2. Turn the fuel cock lever to "OFF".
3. Clean with solvent.
4. Wipe off.
5. Check the gasket. Replace it if damaged.

!WARNING

Be sure the fuel cock cup is tightened securely.

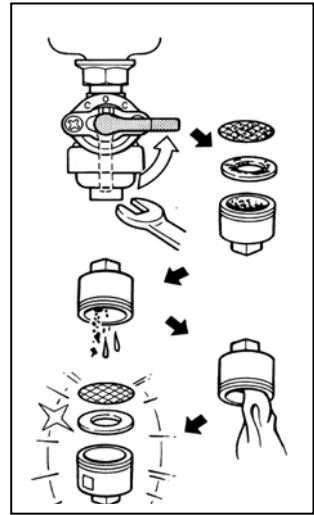

6) FUEL TANK FILTER

- ① Clean with solvent.
- ② Wipe off.
- ③ Fuel tank filter.

!WARNING

Be sure the tank cap is tightened securely.

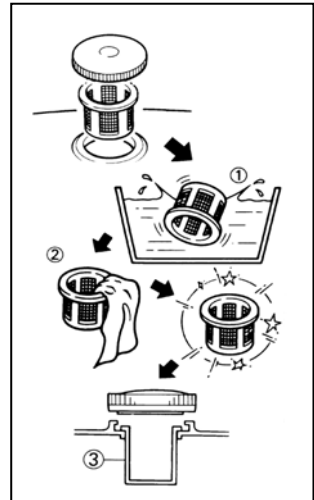

7) MUFFLER SCREEN

!WARNING

- The engine and muffler will be very hot after the engine has been run.
- Avoid touching the engine and muffler while they are still hot with any part of your body or clothing during inspection or repair.

1. Remove the muffler protector and muffler screen.
2. Clean the carbon deposits out of the muffler screen using a wire brush.
3. Check the muffler screen. Replace it if damaged.
4. Install the muffler screen and muffler protector.

- ① Muffler protector
- ② Muffler screen

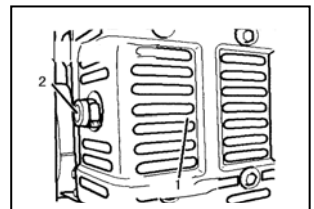

6. TROUBLE SHOOTING

ENGINE TROUBLE SHOOTING

Condition

Probable Cause

Corrective Action

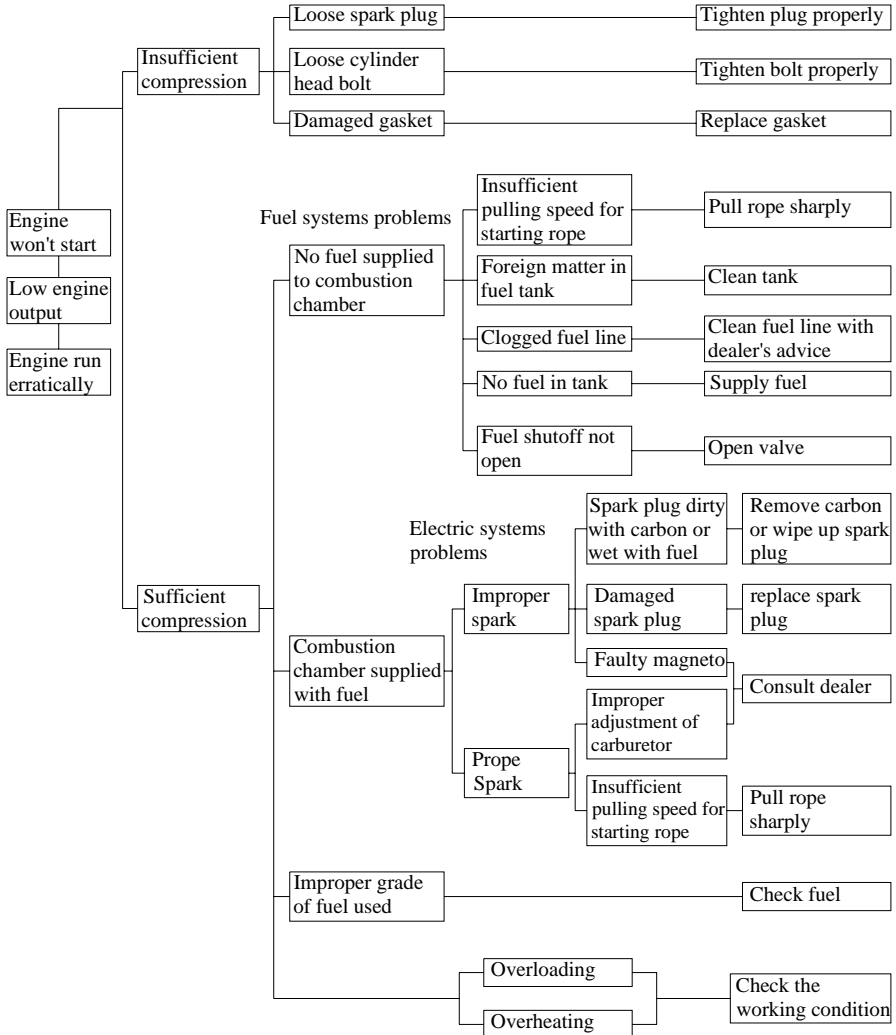

GENERATOR TROUBLE SHOOTING

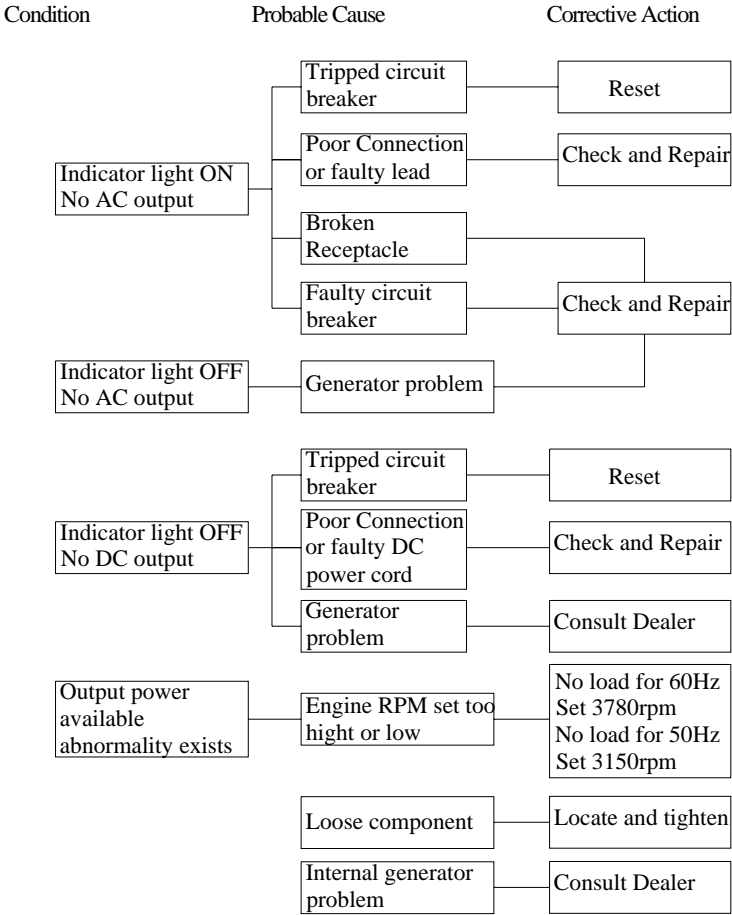

1) Engine won't start

1. Fuel systems

No fuel supplied to combustion chamber.

- No fuel in tank....Supply fuel.
- Clogged fuel line....Clean fuel line.
- Foreign matter in fuel cock....Clean fuel cock.
- clogged carburetor....Clean carburetor.

2. Engine oil system

Insufficient

- Oil level is low....Add engine oil.

3. Electrical systems

Poor spark

- Spark plug dirty with carbon or wet....Remove carbon or wipe spark plug dry.
- Faulty ignition system....Consult dealer.

4. Compression insufficient

- Worn out piston and cylinder....Consult dealer.
- Loose cylinder head nuts....Tighten nuts properly.
- Damaged gasket....Replace gasket.

7. STORAGE

Long term storage of your machine will require some preventive procedures to guard against deterioration.

1) DRAIN THE FUEL

1. Drain the fuel tank, fuel cock, and carburetor float bowl.
2. A cup of SAE 10W30 or 20W40 motor oil.
3. Shake the tank.
4. Drain off the excess oil.

2) ENGINE

5. Pour in about one tablespoon of SAE 10W30 or 20W40 motor oil.
6. Use the recoil starter to turn the engine over several times (with ignition off).
7. pull the recoil starter until you feel compression.
8. Stop pulling.
9. Clean exterior of the generator and apply a rust inhibitor.
10. Store the generator in a dry, well-ventilated place, with the cover place over it.
11. The generator must remain in a vertical position.

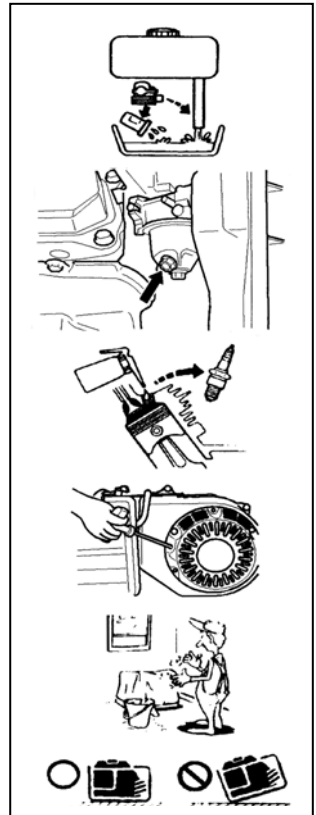

8. SPECIFICATION

MODEL		GS1000W	GS3000W	GS4500W	GS5500W	
GENERATOR	Type	Brushless, Revolving Field, Self-exciting, 2-poles, Single phase				
	AC Voltage	120V	120/240V			
	Frequency	60Hz				
	Max. Output	1.0 kVA	3.0 kVA	4.5 kVA	5.0 kVA	
	Rated Output	0.95 kVA	2.8 kVA	4.0 kVA	4.5 kVA	
	Voltage Regulator	Condenser Type				
	Power Factor	1.0				
	DC Output	12V / 8.3A		12V / 10A		
ENGINE	Model	GS24	GS65	GS130	GS130	
	Type	Air-cooled, 4 cycle, OHV, Gasoline Engine				
	Bore × Stroke mm × mm	54 × 38	68 × 54	88 × 64		
	Displacement	87cc	196cc	389cc		
	Max. Output	2.4HP/4000rpm	6.5HP/4000rpm	13.0HP/4000rpm		
	Fuel	Regular Automobile Gasoline				
	Fuel tank Capacity	4.8 liters	12 liters	22 liters		
	Rated Continuous Operation	60Hz	5.5 hours	10 hours	10 hours	9.2 hours
	Lubricating oil	Engine Oil SD Class or Higher				
	Lubricating oil Capacity	0.4 liter	0.6 liter	1.1 liter		
	Starting System	Recoil Starter				
	Ignition system	T.C.I.				
	Spark Plug: Type	E6TC BPR7HS(NGK)	F6RTC BPR6ES (NGK)			
DIMENSION	Net dimension L × W × H	445 × 350 × 365 mm	545 × 425 × 440 mm	674 × 510 × 532 mm		
	Overall dimension L × W × H	460 × 365 × 385 mm	560 × 440 × 460 mm	690 × 530 × 550mm		
	Net Weight	28 Kg	45 Kg	75 Kg	75 Kg	
	Dry Weight	30 Kg	48 Kg	78 Kg	78 Kg	

- Specifications subject to change without prior notice.

MODEL		GSE5000W	GS6500W	GSE6000W
GENERATOR	Type	Brushless, Revolving Field, Self-exciting, 2-poles, Single phase		
	AC Voltage	120/240V		
	Frequency	60Hz		
	Max. Output	5.0 kVA	6.5 kVA	6.5 kVA
	Rated Output	4.5 kVA	5.5 kVA	5.5 kVA
	Voltage Regulator	Condenser Type		
	Power Factor	1.0		
	DC Output	12V / 10A		
ENGINE	Model	GS130	GS130	GS130
	Type	Air-cooled, 4 cycle, OHV, Gasoline Engine		
	Bore × Stroke mm × mm	88 × 64		
	Displacement	389cc		
	Max. Output	13.0HP/4000rpm		
	Fuel	Regular Automobile Gasoline		
	Fuel tank Capacity	22 liters	22 liters	22 liters
	Rated Continuous Operation	8.5 hours	7.0 hours	7.0 hours
	Lubricating oil	Engine Oil SD Class or Higher		
	Lubricating oil Capacity	1.1 liter		
	Starting System	Recoil + Self Starter	Recoil	Recoil + Self Starter
	Ignition system	T.C.I.		
	Spark Plug: Type	F6RTC BPR6ES (NGK)		
DIMENSION	Net dimension L × W × H	725 × 510 × 532 mm		
	Overall dimension L × W × H	740 × 530 × 550 mm		
	Net Weight	78 Kg	84 Kg	87 Kg
	Dry Weight	80 Kg	87 Kg	90 Kg

- Specifications subject to change without prior notice.

9. WIRING DIAGRAM

Remark : Specifications subject to change without prior notice.

Symbol	Parts Name	Symbol	Parts Name	Symbol	Parts Name
E/G	Engine	G/R	Generator	C-BOX	Control box
ENG.SW	Engine stop switch	MC	AC winding	AC SW	AC switch
OS	Oil level gauge	SC	Auxiliary winding	V	Voltmeter
OSU	Oil warning unit	FC	Field winding	REC	AC socket
T.C.I.	T.C.I. unit	DC	Charge winding	CB	DC Circuit break
SP	Spark plug	D1	Rectifier	D2	Rectifier
PL	Oil pilot lamp				
D3	Rectifier				
M	Starter motor				
SR	Starter relay				

GS1000W (Single Voltage Type)

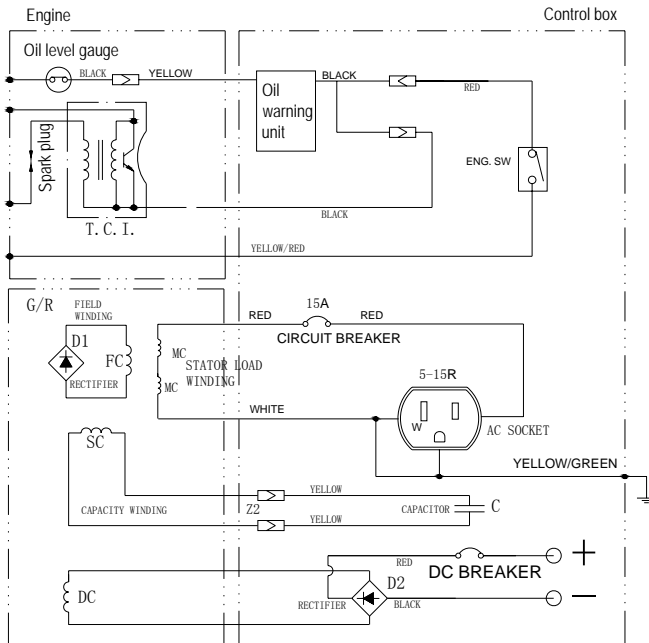

GS3000W

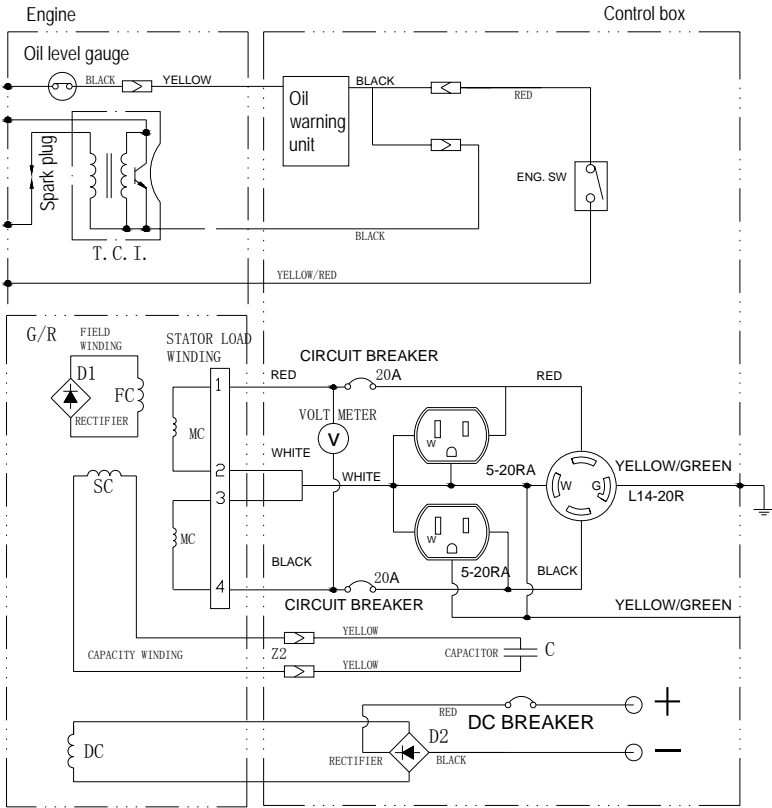

GS4500W, GS5500W

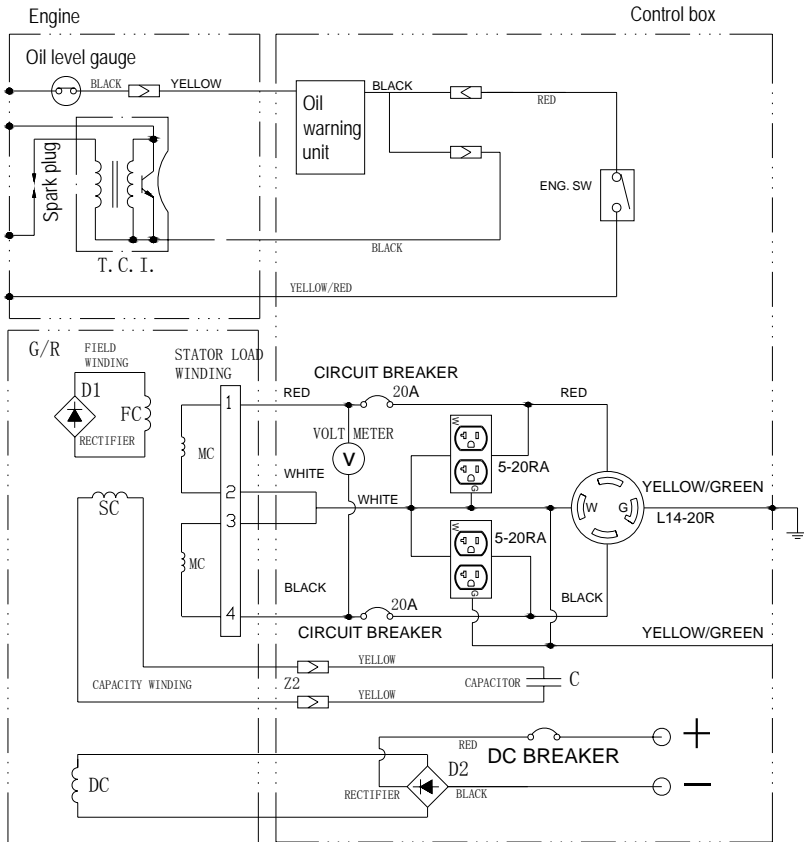

GS6500W

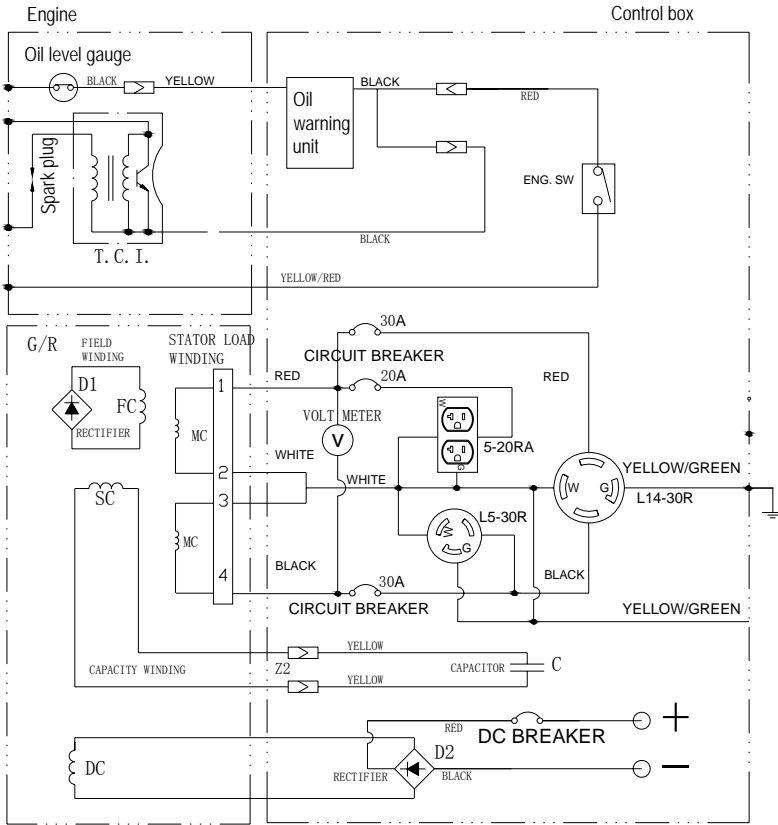

GSE5000W

