

P3-POWER™

GS1001i

Operating Manual / Manual d'operation



PREFACE

Thank you for purchasing our generator.

This manual covers operation and maintenance of GS1001i.

All information in this publication is based on the latest product information available at the time of approval for printing.

We reserve the right to make changes at any time without notice and without incurring any obligation.

No part of this publication may be reproduced without written permission.

This manual should be considered a permanent part of the generator and should remain with it if it is resold.

Pay special attention to statements preceded by the following words;

⚠ WARNING

It indicates a strong possibility of severe personal injury or death if instructions are not followed

⚠ WARNING

It indicates a strong possibility of severe personal injury or death if instructions are not followed

If a problem should arise, or if you have any questions about the generator, consult an authorized dealer.

⚠ WARNING

The generators are designed to give safe and dependable service if operated according to instructions. Read and understand the Owner's Manual before operating the generator. Failure to do so could result in personal injury or equipment damage.

SAFETY INSTRUCTIONS

⚠ WARNING

The generator is designed to give safe and dependable service if operated according to instructions. Read and understand this manual carefully before operating the generator, or it may cause serious injury and equipment damage.

⚠ WARNING

Exhaust contains poisonous carbon monoxide. Do not operate generator in confined area. Be sure to operate the generator in a well-ventilated environment or with an aerator. Using a generator indoors will kill you in minutes. Never use in the home or in a partly enclosed area such as garages. Only use outdoors and far from open windows doors and vents.

⚠ WARNING

The muffler becomes very hot during operating and remains hot for a while after stopping the engine. Be careful not to touch the muffler while it is hot. Let the engine cool before storing the generator indoor.

The engine exhaust system will be heated during operation and remain hot immediately after stopping the engine.

To prevent burns, pay attention to the warning marks attached to the generator.

⚠ WARNING

Do not parallel connect other cables to receptacles, use special jack, or it may cause an electrical shock.

⚠ WARNING

Gasoline is extremely flammable and is explosive under certain conditions. Refuel in a ventilated area with engine stopped. Keep away from cigarette, smoke and sparks when refueling the generator. Always refuel in a well-ventilated location.

⚠ WARNING

Connection for standby power to a building electrical system must be made by a qualified electrician. The connection must isolate the generator from utility power, and must comply with all applicable laws and electrical codes. Improper connections to a building electrical system can allow electrical current from the generator to backfeed into the utility lines. Such backfeed may electrocute utility company workers or others who contact the lines during a power outage, and the generator may explode, or cause fires when utility power is restored.

⚠ WARNING

To avoid accidents and equipment damage, check generation system time before starting engine. Keep the generator a distance of at least 1 yard from other equipment during operation. Keep the generator horizontal when running. If generator tilts, fuel may leak. Generator operators must be trained, must know how to stop the generator quickly and understand the operation of all controllable parts. Untrained operators should not be allowed to use this equipment. Keep children and pets away from operation area. Keep away from rotating parts during operation. The generator is a potential source of electrical shock when misused. Do not operate it with wet hands or in any wet location. Do not operate the generator in rain or snow and let it get wet.

Safety Label and Locations

These labels warn you of potential hazard that can cause serious injury. Read the labels and safety notes and precautions described in manual carefully.

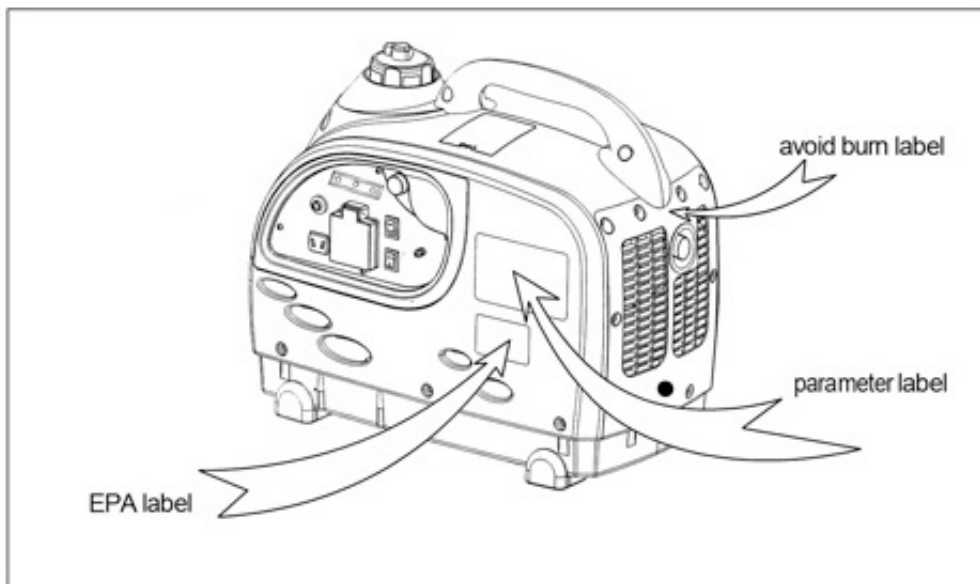
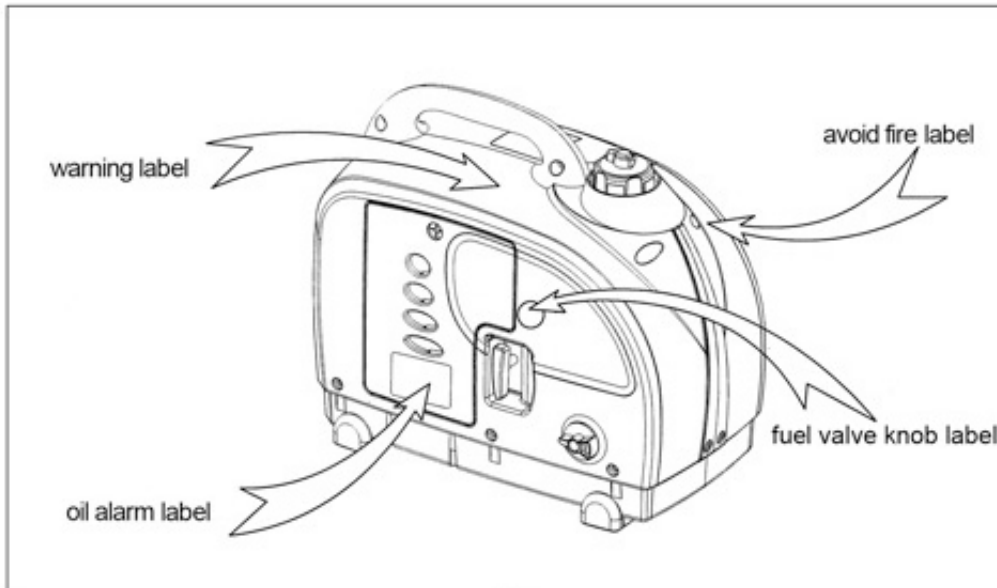

Component Identification

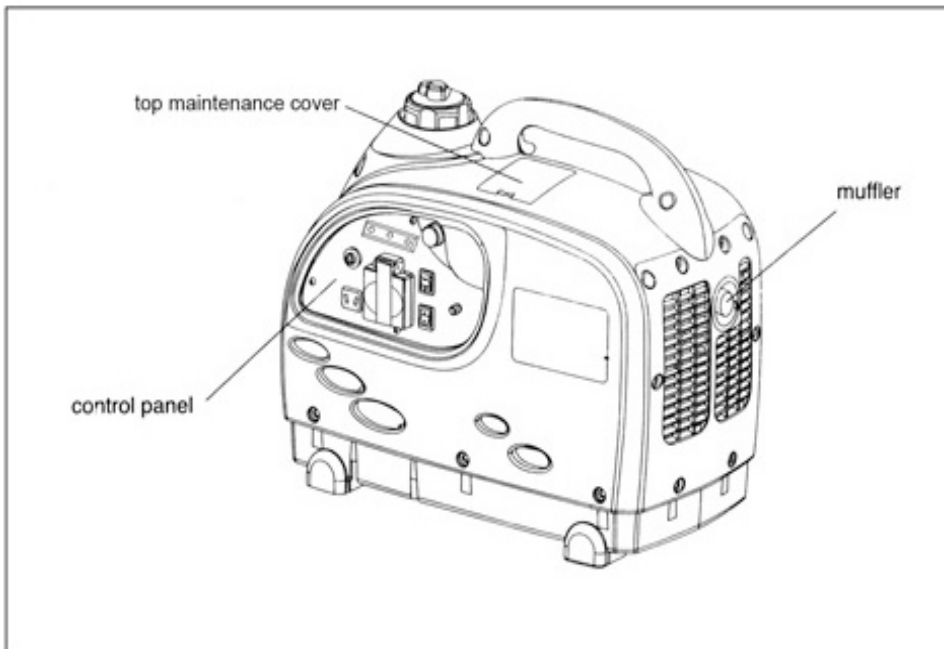
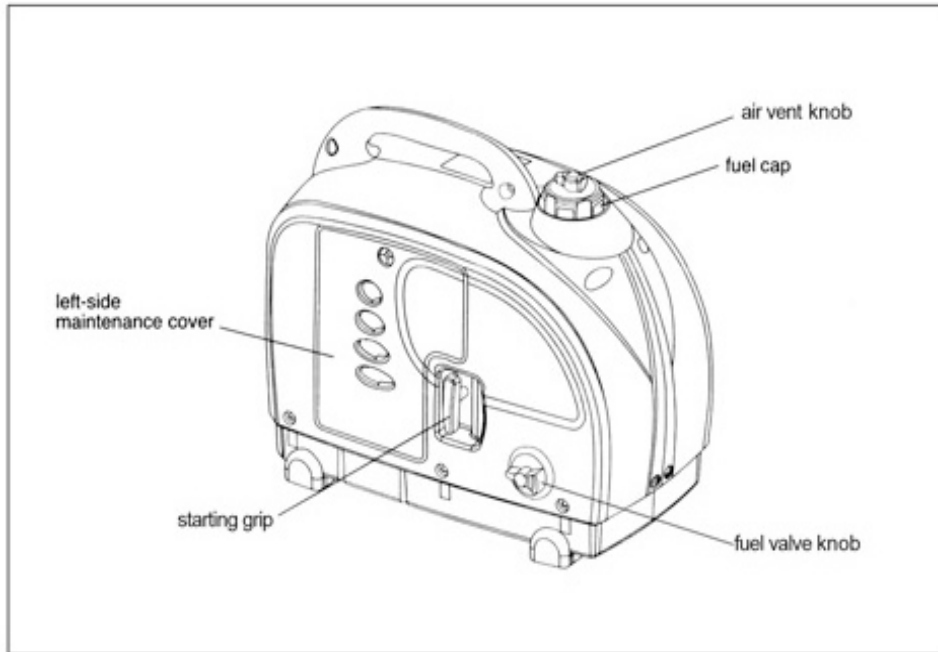

Control panel

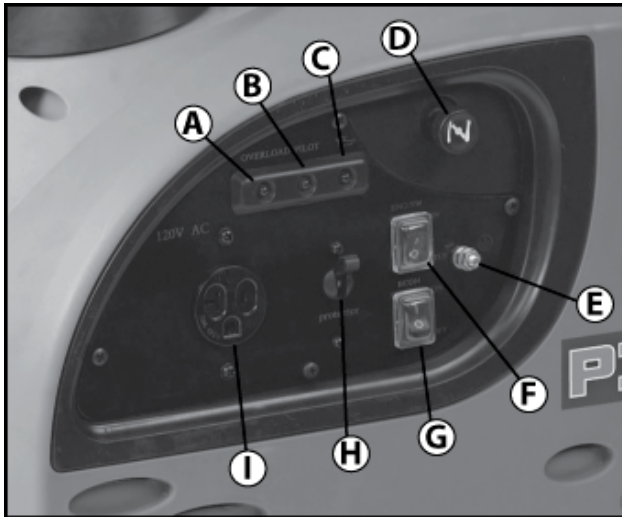

- A – Overload indicator
- B – Output indicator
- C – Oil alarm indicator
- D – Choke knob
- E – Ground terminal
- F – Engine switch
- G – ECONO switch
- H – Circuit breaker
- I – AC receptacle

Smart Throttle – ECONO switch (G)

To minimize fuel consumption during operation, the engine automatically idles when the electrical appliance is disconnected. It will return to the proper speed when the electrical appliance is connected.

⚠ WARNING

Smart throttle system does not operate effectively, if the electrical appliance requires momentary electric power.

When high electrical loads are connected simultaneously, turn the Smart throttle switch to the OFF position to reduce voltage vibration.

Pre-operation check

⚠ CAUTION

Be sure the generator is on a level surface with engine stopped before starting.

1. Check engine oil level

⚠ BE CAREFUL

Engine oil is a major factor affecting engine performance and service life. Using non-detergent and 2-stroke engine oils will damage the engine and are not recommended, and will void warranty!

Use high-detergent, qualified 4-stroke engine oil, certified to meet or exceed U.S. automobile manufacture's requirements for API Service Classification SG, SF. Select the appropriate viscosity for the average temperature in your area.

SAE viscosity grades:

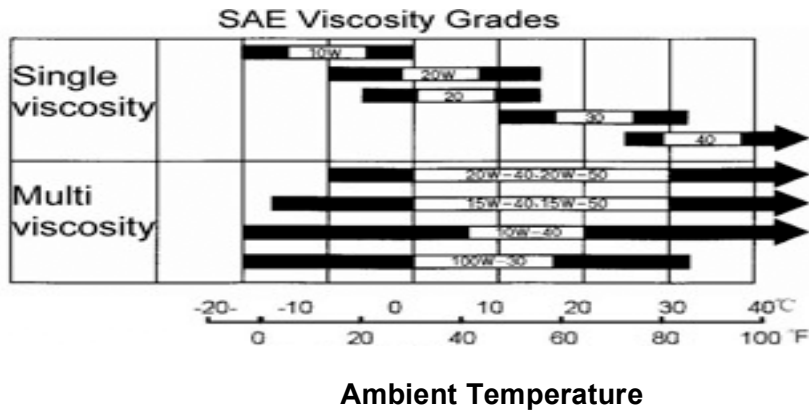

Remove the oil filler cap and wipe the dipstick with a clean rag. Check the oil level by inserting the dipstick in the filler hole without screwing it in. If the oil level is below the end of the dipstick, refill the recommended oil up to the top of the oil filler neck.

⚠ BE CAREFUL

Running the engine with insufficient oil can cause serious engine damage. The Low Alarm System will automatically stop the engine before the oil level falls below the safe limit. To avoid the inconvenience of an unexpected shutdown, it is still advisable to visually inspect the oil level regularly.

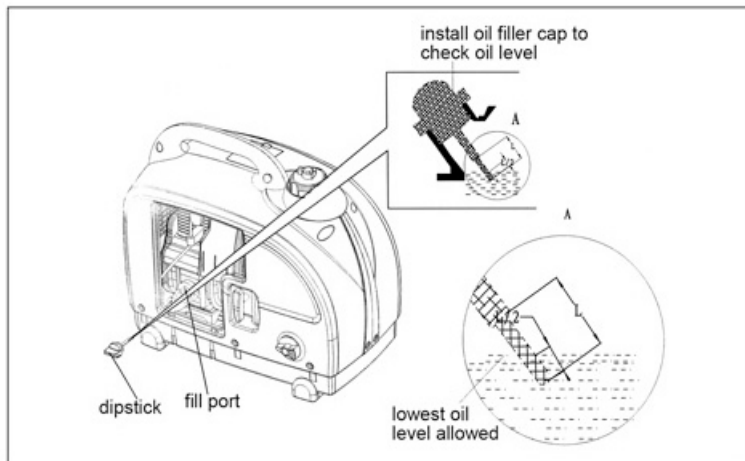

2. Check the fuel level

Use automotive gasoline (unleaded gasoline is required to minimize combustion chamber deposits) If the fuel level is low, refuel until the level is increased to the specified mark.

Never use stale or contaminated gasoline or an oil/gasoline mixture.

Avoid getting dirt and water in the fuel tank.

Tighten the fuel filler cap securely after adding fuel.

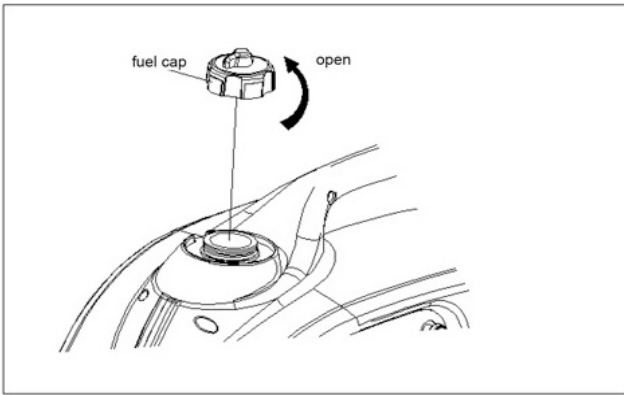

When transporting, turn the air vent knob to the OFF position.

⚠ WARNING

Gasoline is extremely flammable and is explosive under certain conditions. Do not smoke or allow flames or sparks where the generator is refueled or where gasoline is stored. Refuel in a well-ventilated area with the engine stopped. Do not overfill the fuel tank (there should be no fuel above the upper limit mark). After refueling, make sure the tank cap is closed properly and securely. Be careful not to spill fuel while filling the tank. Spilled fuel or fuel vapor may ignite. If fuel spills, wipe away until dry. Do not start the engine until area is dry and vapor free. Avoid prolonged and repeated contact with gas or breathing of vapor. Keep out of reach of children.

3. Check air filter

Check air filter, and be sure it's clean and works well.

- a. Loosen the cover screw and remove the maintenance cover
- b. Loosen the screw under the air filter box.
- c. Pull the air filter cover down 1.25 inches according to (a) and remove the air filter cover according to (b).
- d. Remove the air filter iron clip and element. Clean and change the air filter element if necessary.
- e. Clean or replace the air filter element after reinstalling air filter

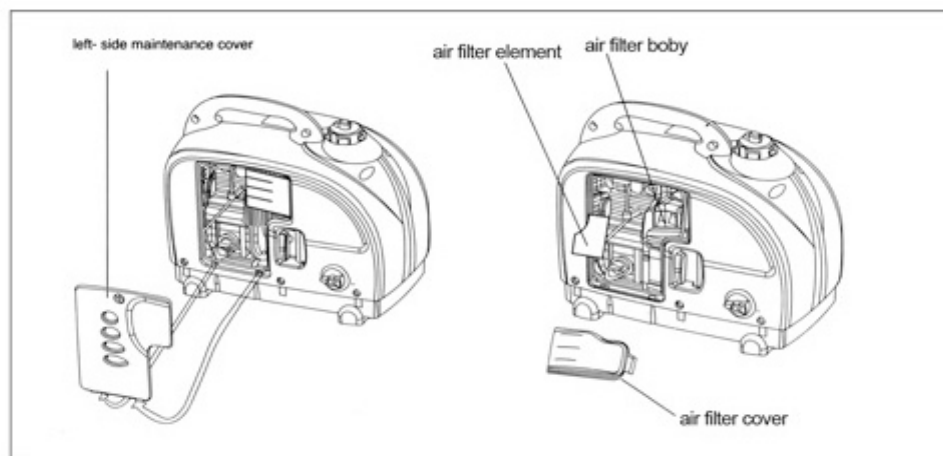

⚠ BE CAREFUL

Never operate the engine without the air filter. Rapid engine wear will result from contaminants, such as dust and dirt, being drawn through the carburetor into the engine.

It is normal for a little oil to appear under the air filter box if the generator is running for a long period of time, or there is a lot of oil in the engine. Wipe up excess oil after each use and after stopping the generator.

Start the engine

Before starting the engine, disconnect any plug from the AC socket.

Turn the air vent knob on the fuel cap counter-clockwise

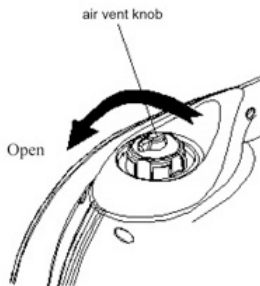

Turn the fuel valve knob to the ON position

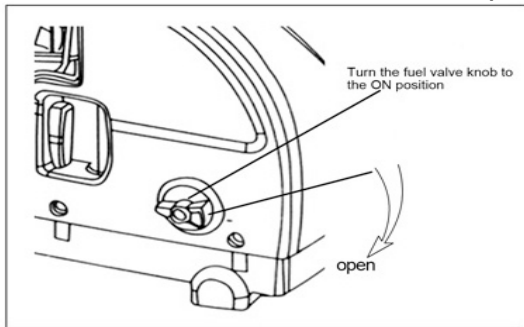

To start a cool engine, pull out the choke knob (D) completely to the CLOSED position. To restart a warm engine. Press the choke knob in completely to the OPEN position.

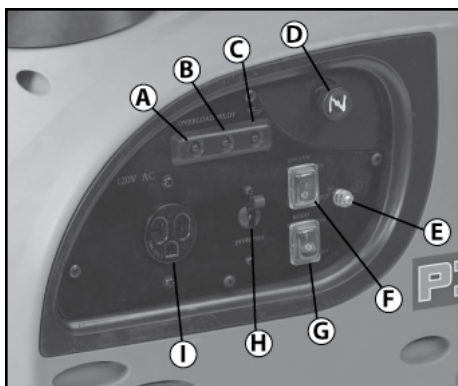

⚠ BE CAREFUL

Controlling the choke position is the key to starting the engine; it may take several practice attempts before you master the choke.

To restart a hot engine, leave the choke in the OPEN position or pull it out half way. To restart a warm engine, pull out the choke 1/3 or 1/2 way.

A hot engine will not start if there is too much gasoline in the cylinder. If this happens, wait 5-10 minutes before retrying. Press the choke in completely to the OPEN position and the engine should start.

The engine will stop automatically when it is out of gasoline. Refuel accordingly to the instructions defined earlier in this manual. To restart the engine after refueling pull the choke out completely, then pull the starting handle 2 or 3 times so that gasoline enters the carburetor. Adjust the choke according to the above instructions. 4. Turn the engine switch (F) to the ON position.

Pull the starting grip lightly until resistance is felt, then pull briskly.

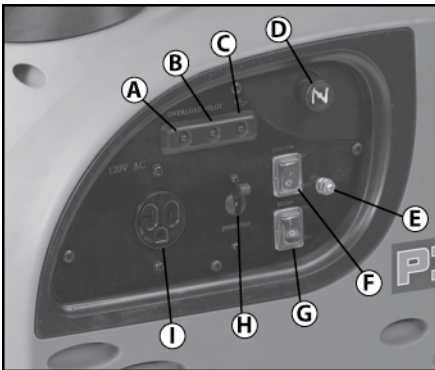

⚠ BE CAREFUL

Never allow the starting grip to snap back, return it slowly by hand.

Grasp the carrying handle firmly to prevent the generator from falling over when pulling the starting grip.

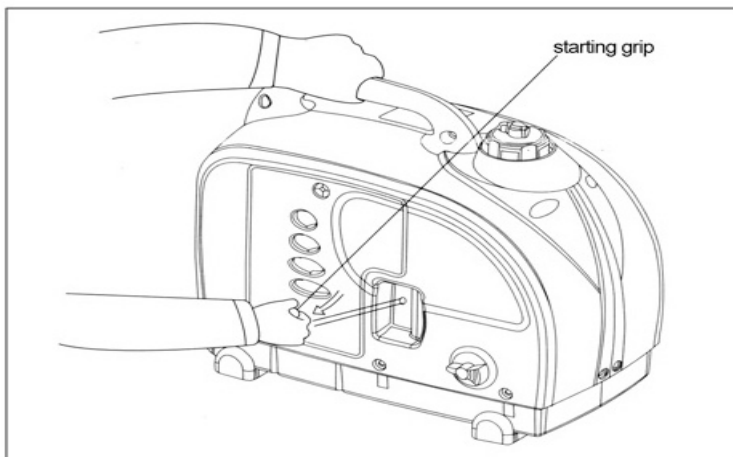

After the engine starts, allow the engine to run continuously and warm up. Press the choke (D) in completely after the engine is started.

Note

If the engine stops and will not restart, check the engine oil level before troubleshooting in other areas.

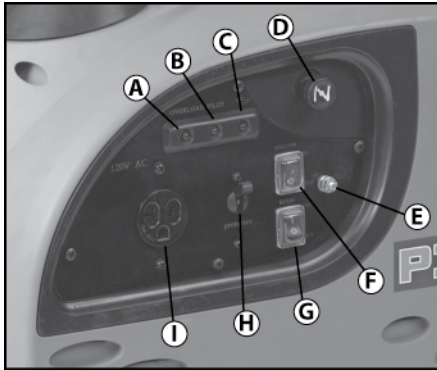

High Altitude Operation

At high altitude, the standard carburetor air-fuel mixture will be excessively rich. Performance will decrease, and fuel consumption will increase.

High altitude performance can be improved by installing a smaller diameter main fuel jet in the carburetor and by readjusting the screws. If you always operate the generator at altitudes higher than 1500m(5000feet) above sea level, have your authorized dealer perform these carburetor modifications.

Even with suitable carburetor setting, engine horsepower will decrease approximately 3.5% for each 300m(1000 feet) increase in altitude. The affect of altitude on the horsepower will be greater than this if no carburetor modification is made.

Note

Operation of the generator at an altitude lower than the carburetor is set for may result in reduced performance, overheating, and serious engine damage caused by an excessively lean air/fuel mixture

Generator Use

⚠ BE CAREFUL

Do not exceed the rated power.

Total wattage of all appliances connected must be considered.

Do not exceed the current limit specified for any one socket.

Do not generator to any household circuit, otherwise, it may destroy generator or home electric equipment.

Do not use generator for any purpose other than its intended use, Failure to follow these instructions could result in serious injury. Do not parallel connect generators or lengthen the exhaust pipe.

Extension cords are not recommended. If an extension cable is required, be sure to use only a rubber sheathed flexible cable. (IEC245 or equivalent)

Limit length of extension cables: 60m for cable of 1.5mm and 100m for cables of 2.5mm.

Long extension cables will reduce usable power due to resistance in the extension cable.

Keep the generator away from other electric cables or wires such as commercial power supply lines.

Note

Most appliance motors require more than their rated wattage for start-up

AC power use

1. Start the engine and make sure the output indicator (green - B) stays on.
2. Insure that all loads have been turned off, and then put the plug into the socket.

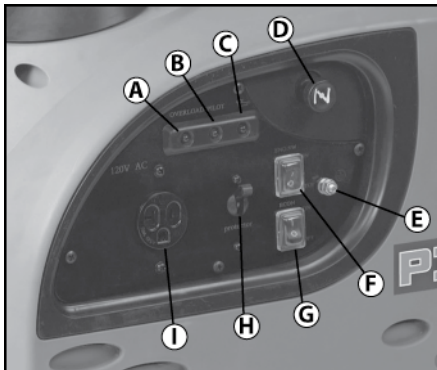

⚠ BE CAREFUL

Substantial overloading that continuously lights the overload indicator light (red - A) may damage the generator. Marginal overloading that temporarily lights the overload indicator light (red - A) may shorten the service life of the generator.

Be sure that all appliances are in good working order before connecting them to generator. If an appliance begins to operate abnormally, becomes sluggish or stops suddenly, turn it off immediately, disconnect the appliance, and determine whether the appliance has a problem, or if the rated load capacity of the generator has been exceeded.

Output and overload indicator:

The output indicator (green - B) will remain ON during normal operating conditions.

If the generator is overloaded (in excess of 1 kva), or there is a short circuit in a connected appliance, the overload indicator (red - A) will go on. The overload indicator (red - A) will stay on, and the current to the connected appliance will be shut off.

STOP THE ENGINE IMMEDIATELY IF THE OVERLOAD INDICATOR LIGHT TURNS ON

Do not restart until you have found the reason for the overload.

⚠ BE CAREFUL

BEFORE CONNECTING ANY APPLIANCE TO THE GENERATOR, BE SURE IT IS IN PROPER WORKING ORDER AND THAT IT DOES NOT EXCEED THE POWER RATING OF THE GENERATOR.

Be sure all equipment is turned off before plugging in the power cord.

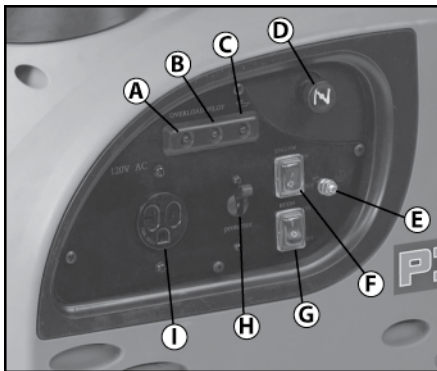

⚠ BE CAREFUL

When an electric motor is started, both the overload indicator (red - A) and the output indicator (green - B) may stay on simultaneously. This is normal if the overload indicator (red - A) stays off after about 4 seconds.

If the overload indicator (red) stays on after the engine has been started, discontinue use and consult an authorized repairperson. **DO NOT CONTINUE TO USE.**

1. Connect ground

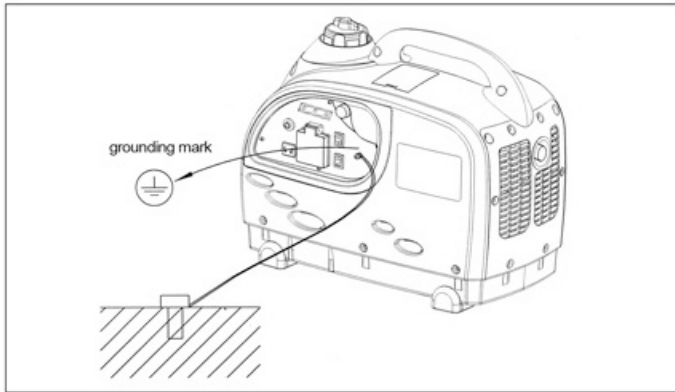

2. Start the engine

If the overload indicator stays on, TURN OFF THE ENGINE IMMEDIATELY. Restart the engine after the overload indicator turns off.

3. Make sure the electrical appliance is turned off, before plugging it in the AC socket.

⚠ BE CAREFUL

BE SURE ALL APPLIANCES ARE IN THE OFF POSITION BEFORE CONNECTING TO THE GENERATOR. FAILURE TO DO SO MAY RESULT IN SERIOUS INJURY, DEATH, AND EQUIPMENT DAMAGE. ALWAYS KEEP UNTRAINED PEOPLE, CHILDREN AND PETS AWAY FROM THE GENERATOR WHILE IN USE.

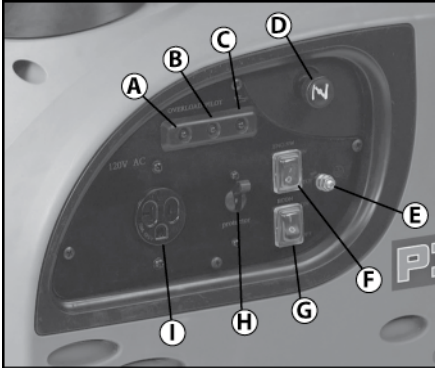

4. Turn on the equipment after output indicator (green - B) turns on

If there is overload or malfunction in equipment, output indicator (green - B) will turn off and overload indicator (red - A) will turn on with no power output. TURN THE ENGINE OFF IMMEDIATELY and follow the instructions above.

⚠ BE CAREFUL

If the equipment is an inductive load, it will need more power for starting. Overload indicator and output indicator lights will turn on at the same time for a short period, that's normal. Red indicator turns off but the green indicator stays on after equipment starts.

Application range:

AC	Electric lamps	Power tools	Electromotor
Power factor	1	0.8-0.9	0.4-0.7 (efficiency 0.85)
GS1001i	-900	-720	-360

Oil alarm system (C)

The oil alarm system is designed to avoid engine damage from lack of oil in crankcase. The oil alarm system will stop the engine automatically before oil level in crankcase gets below the safe level (ignition indicator will stay on during cranking)

The engine will not restart after it is stopped by the oil alarm system. If the oil alarm system indicator (red) stays on during cranking, the engine will not start. Add more oil (see pre-operation check)

Stop engine

To stop engine in an emergency, simply turn engine switch (F) to the OFF position.

Normal usage

1. Unplug appliances from the generator sockets.

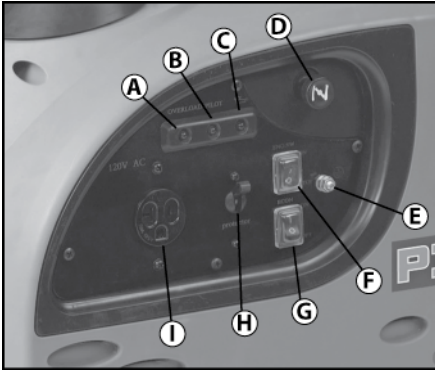

2. Turn the engine switch (F) to the OFF position.
3. Close the air vent knob and turn fuel valve to the OFF position

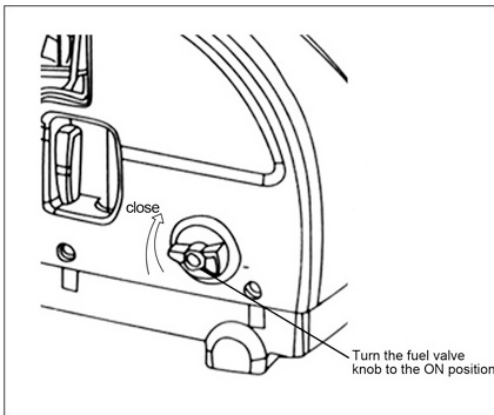

⚠ BE CAREFUL

Make sure that the air vent knob and fuel cap are closed and engine switch is off when finished using, transporting and storing the generator.

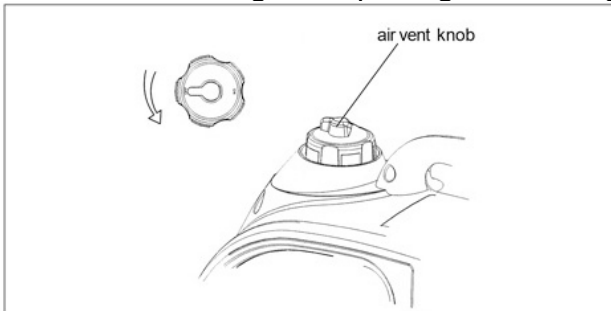

Maintenance Schedule

The purpose of the maintenance and adjustment schedule is to keep the generator in the best operating condition. Inspect or service as scheduled in the table below

⚠ WARNING

Stop engine before servicing. If servicing requires operating generator, be sure to operate the generator in a ventilated environment. Exhaust fumes contain the poisonous gas carbon monoxide. Carbon Monoxide is a colorless, odorless gas that, if inhaled, can cause serious injury or death.

⚠ CAUTION

Repairs to the generator should be done by trained people only.

Perform at every indicated month or operating hour interval.

ITEM	Maintenance procedure					
		Each use	Each month or 20HRS	Every 3 months or 50HRS	Every 6 months or 100HRS	Each year or 200HRS
Engine Oil	Check	●				
	Replace		●		●	
Air cleaner	Check	●				
	Clean			●②		
Spark plug	Clean & adjust				●	
Combustion chamber	Clean				●	
Valve clearance	Check & adjust					●②
Fuel tank and filter tank	Clean					●②
Fuel line	Check	Every 2 years (replace if necessary)				

(1) Normal maintenance interval

(2) Service more frequently when used in dusty areas.

The Maintenance Schedule is based on the 25⁰C. If the temperature is above 30⁰C, decrease the output power or shorten the time to change oil.

Temperature (°C)	Time for changing oil (hour)	Recommended power factor
25	Normal	100%
30	18	95%
35	15	85%
40	12	70%

Change oil

Drain the used oil while the engine is warm. Warm oil drains quickly and completely.

⚠ BE CAREFUL

Turn the engine switch and air vent knob to the OFF position to reduce the possibility of fuel leakage.

Tilt the generator.

Loosen the screw and drain the oil completely.

Retighten the screw.

Add the recommended oil and check the oil level

Gently shake the generator to make the float rise after adding new oil.

Oil tank capacity: 0.25L

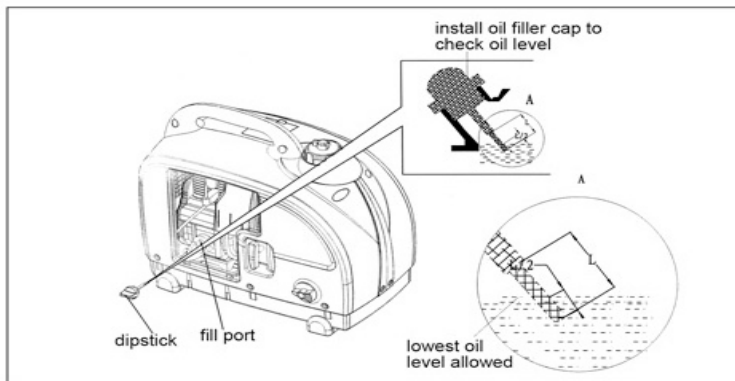
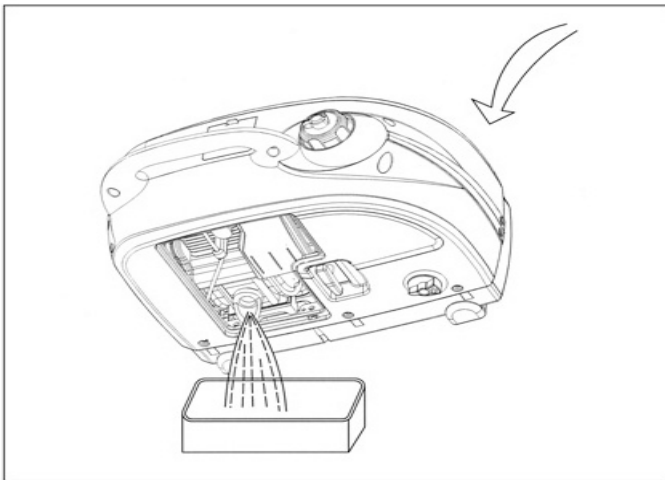

Wash your hands with soap and water after handling used oil

⚠ BE CAREFUL

Dispose of used engine oil in a manner that is compatible with the environment. We suggest you take it in a sealed container to your local service station for reclamation. Do not throw it in the trash or pour it on the ground.

Air filter service

A dirty air filter will restrict airflow to the carburetor. To prevent carburetor malfunction, service the air filter regularly. Service more frequently when operating the generator in dusty areas.

⚠ WARNING

Do not use fuel or low flash point solvents for cleaning. They are flammable and explosive under certain conditions.

- a. Loosen the cover screw and remove the maintenance cover.
- b. Loosen the screw under the air filter box.
- c. Pull the air filter cover down 30mm according to the (a) and remove the air filter cover according to (b)
- d. Remove the air filter iron clip and check the air filter element. Clean or replace the element if necessary.
- e. Reinstall the air filter parts after cleaning or replacing air filter element.

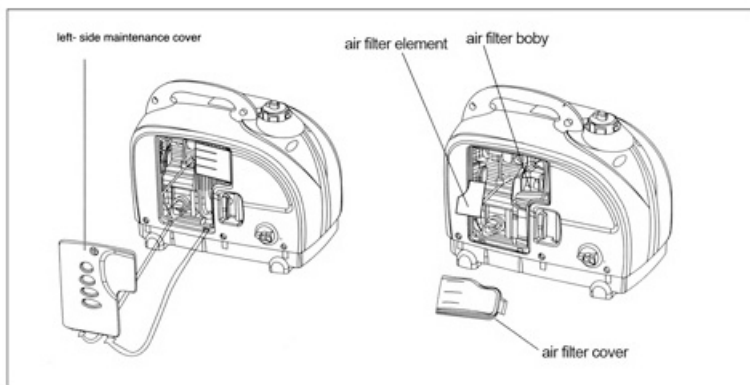

Spark plug servicing

Please use a high quality authentic spark plug.

To ensure proper engine operation, the spark plug must be properly gapped and free of deposits.

Remove the top maintenance cover

Clean any dirt from around the spark plug base

Use a spark plug wrench to remove the spark plug.

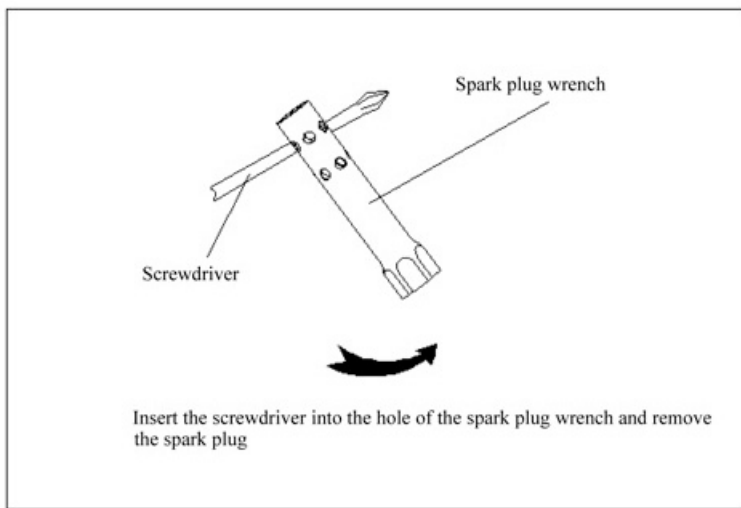
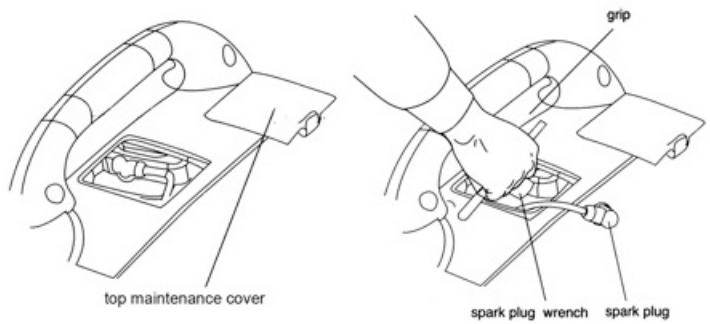

Visually inspect the spark plug. Discard it if the insulator is cracked or chipped. Clean spark plug with a wire brush if it is to be reused. Measure the spark plug gap with plug gauge. It should be 0.6-0.7mm (0.024-0.028inch)

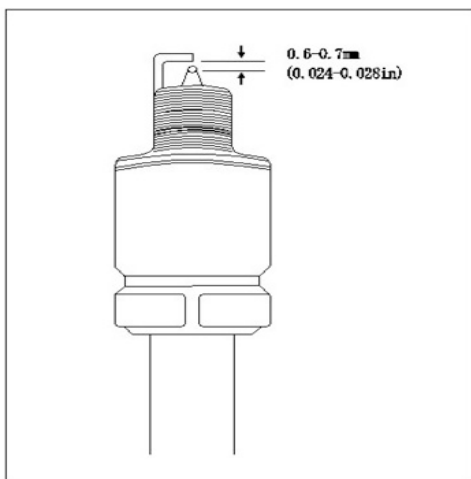

Install the spark plug carefully by hand, to avoid crosses threading.
After a new spark plug has been seated by hand, it should be tightened 1/2 turn with a wrench to compress its washer. If a used plug is being reinstalled, it should only require 1/8 to 1/4 turns after being seated.
Reinstall the spark plug rubber boot on the spark plug securely.
Reinstall the cover panel.

⚠ BE CAREFUL

The spark plug must be securely tightened. An improperly tightened plug can become very hot and possibly damage the generator.
Never use a spark plug with an improper heat range.
Never use a spark plug without damping resistance, or it will cause no AC output.

Transportation and storage

To avoid fuel spillage during transportation and storage, the generator should be secured upright in its normal operation position, with the engine switch OFF. The air vent is turned counterclockwise to the OFF position.
Allow the engine to cool completely before turning the air vent to the OFF position.

⚠ WARNING

Do not overfill the tank. (There should be no fuel in the filler neck).
Do not operate generators while it is on a vehicle. Take the generator off the vehicle and use it in a well-ventilated place.
Avoid direct sunlight when putting the generator in a vehicle, high temperatures inside the vehicle could cause the fuel to vaporize and possibly explode.
Do not drive on a rough road for an extended period with the generator on board.
If you must transport the generator on a rough road, drain the fuel from the generator beforehand.
Before storing the generator:
1) Ensure the storage space is dry and clean 2) Drain all fuel in the tank.

⚠ WARNING

Fuel may become extremely explosive in some conditions. Do not use near open flame or other ignition sources.
Completely drain the fuel from the tank. Open the fuel valve, start the engine and operate it in the idle position until all remaining fuel is gone and the engine shuts off automatically.

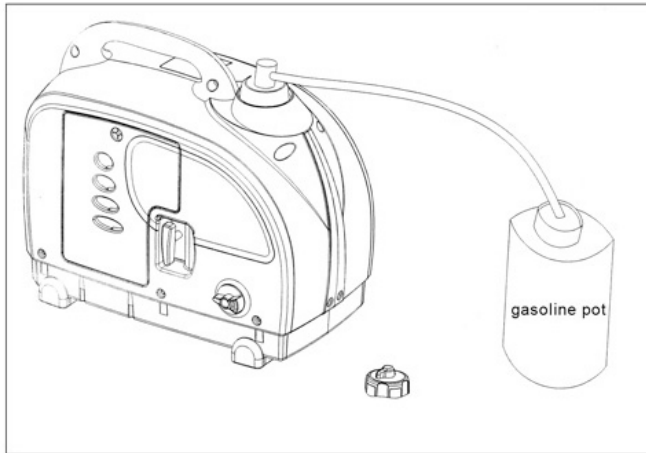

Discharge oil

Remove spark plug and Fill cylinder with 2cc's fresh oil. Pull start motor 3-4 times to discharge the remaining oil. Then reinstall the spark plug.

Pull the starting cord slowly until resistance is strong. At this time, the piston is moving to the top of the compression stroke, and the valves will be closed.

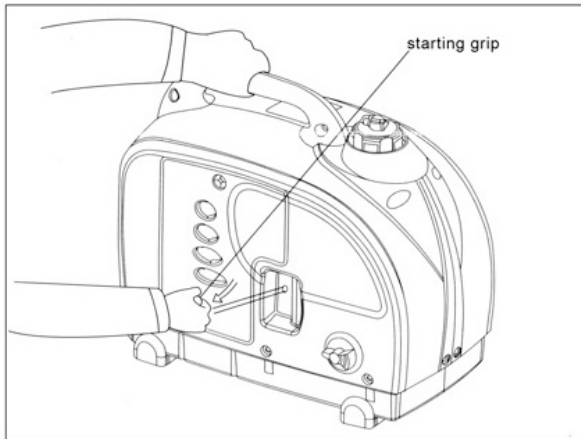

Troubleshooting

Engine will not start:

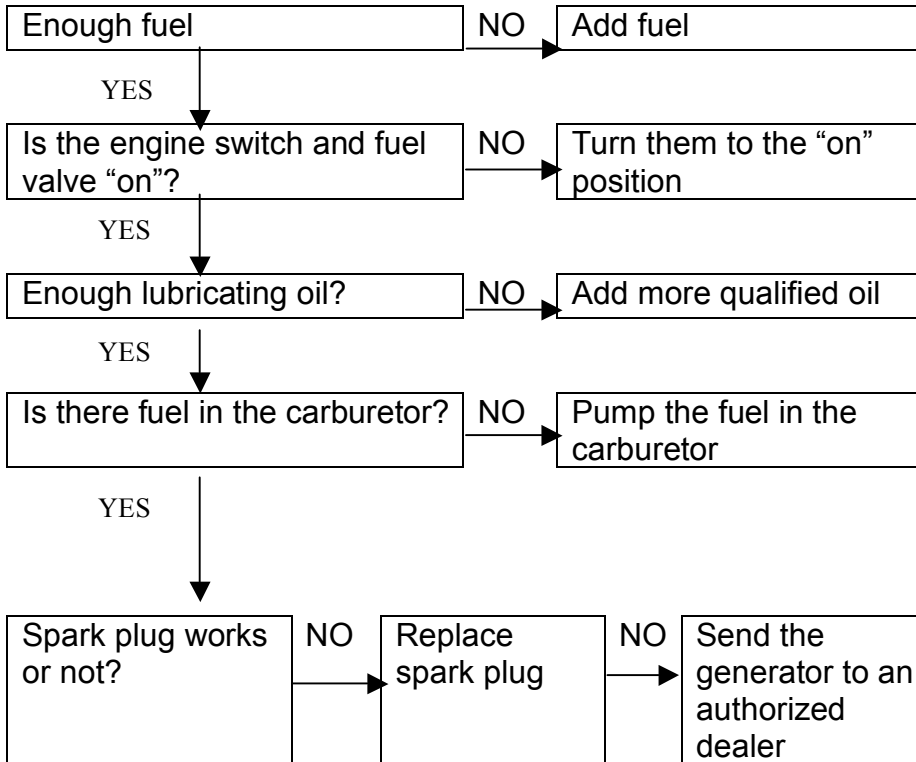

Note

*Shake the generator several times to make the float rise if the generator can't start after adding oil for the first time and the oil alarm indicator stays on when pulling the starting grip.

Warning
*Make sure there is no spilled fuel around the spark plug.
Spilled fuel may ignite.

If the engine still does not start, have the generator repaired by a licensed repairperson.

The equipment that connects the generator does not start

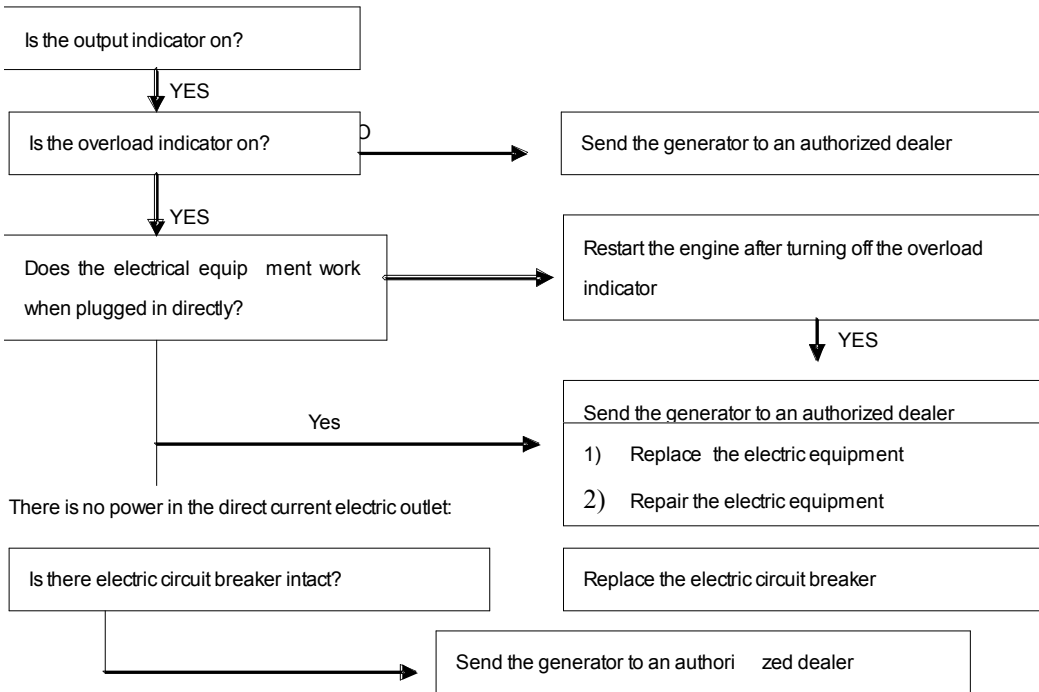

*Deficient AC output

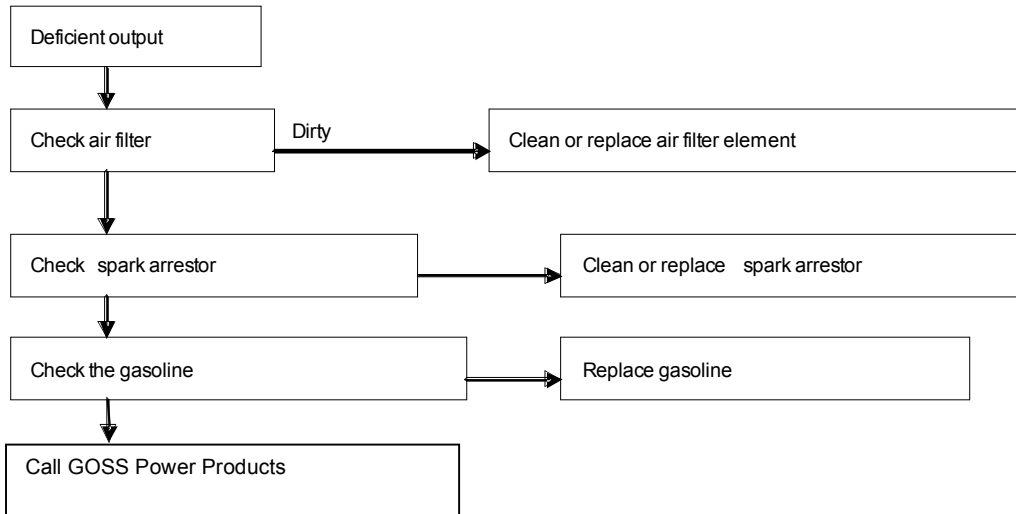

SPECIFICATIONS

Size and weight

Type	GS1001i
L *W *H (mm)	495*275*415
Net weight (kg)	13.7

Engine

Model	144F
Type	4-stroke OHV 1-Cylinder
Displacement (cc)	53
Compression ratio	7.4
Engine speed	5500rpm (ECO switch is off)
Cooling system	Forced air cooling
Ignition system	TDI
Oil capacity (L)	0.25L
Fuel tank capacity (L)	2.5L
Spark plug	NGK
Noise level (db/7m)	58DB

Generator

Type	GS1001i	
AC output	Rated voltage (V)	120
	Rated frequency (HZ)	60
	Rated output (KVA)	0.9
	Maximum output (KVA)	1.0

Parts List

Ref #	Description	Ref #	Description
1	engine	47	M4 x 10 round head screw
2	Ignition timing senser	48	Step motor
3	M5 X 10 flange bolt	49	M3 x 8 round head screw
4	Stator assembly	50	Double head screw
5	M5 x 25 flange bolt	51	Air cleaner box
6	Flywheel assembly	52	Breath pipe
7	M10 x 1.25 nut	53	M5 nut
8	Fan blade	54	Air cleaner sponge
9	clutch joint sleeve	55	Air cleaner cover
10	M6 x 12 fangle bolt	56	Fuel valve
11	Starter cup	57	Left shroud
12	M6 x 16 fangle bolt	58	Access panel
13	Fan blade cover	59	M6 x 16 big head bolt
14	Inginition coil	60	Recoil starter handle
15	ST4.8 x 20 self-taping screw	61	Recoil starter sleeve
16	Recoil Starter	62	Fuel valve knob
17	M6 x 12 fangle bolt	63	Spark plug
18	Outlet pipe	64	Vent bent gasket
19	Fuel tank rubber gasket	65	Vent bent
20	fuel tank insulated sleeve	66	M6 x 20 bolt
21	Fuel tank	67	Right shroud
22	fuel tank sleeve	68	Top maintenance cover
23	Fuel filter	69	Control panel case
24	Fuel tank cap	70	Control panel
25	Fan housing	71	Choke knob assembly
26	M6 x 16 fangle bolt	72	Indicate light
27	Clutch fan	73	Rock switch
28	M10 x 1 nut	74	AC breaker
29	Left shroud	75	AC socket
30	Muffler	76	ST3.2 x 12 self taping screw
31	Right shroud	77	Dipstick
32	Fan cover	78	Engine holder
33	ST3.5 x 12 self taping screw	79	Absorption foot
34	Rear vent air panel	80	CDI box assembly
35	M5 x 16 round head screw	81	Inverter assembly
36	Carburetor gasket (SMALL)	82	Vaccum pipe
37	Rubber gasket	83	Vaccum pump
38	Carburetor gasket (BIG)	84	Engine Inlet pipe
39	Carburetor	85	Pump inlet pipe
40	Choke mount	86	M6 x 16 big head bolt
41	Throttle spring	87	M6 nut
42	Throttle adatper	88	Base
43	Step motor holder	89	M5 x 12 flange bolt
44	M4 x 10 round head screw	90	Outer foot Pads
45	Choke holder 1	91	Fuel filter
46	Choke holder 2		

Exploded Drawing

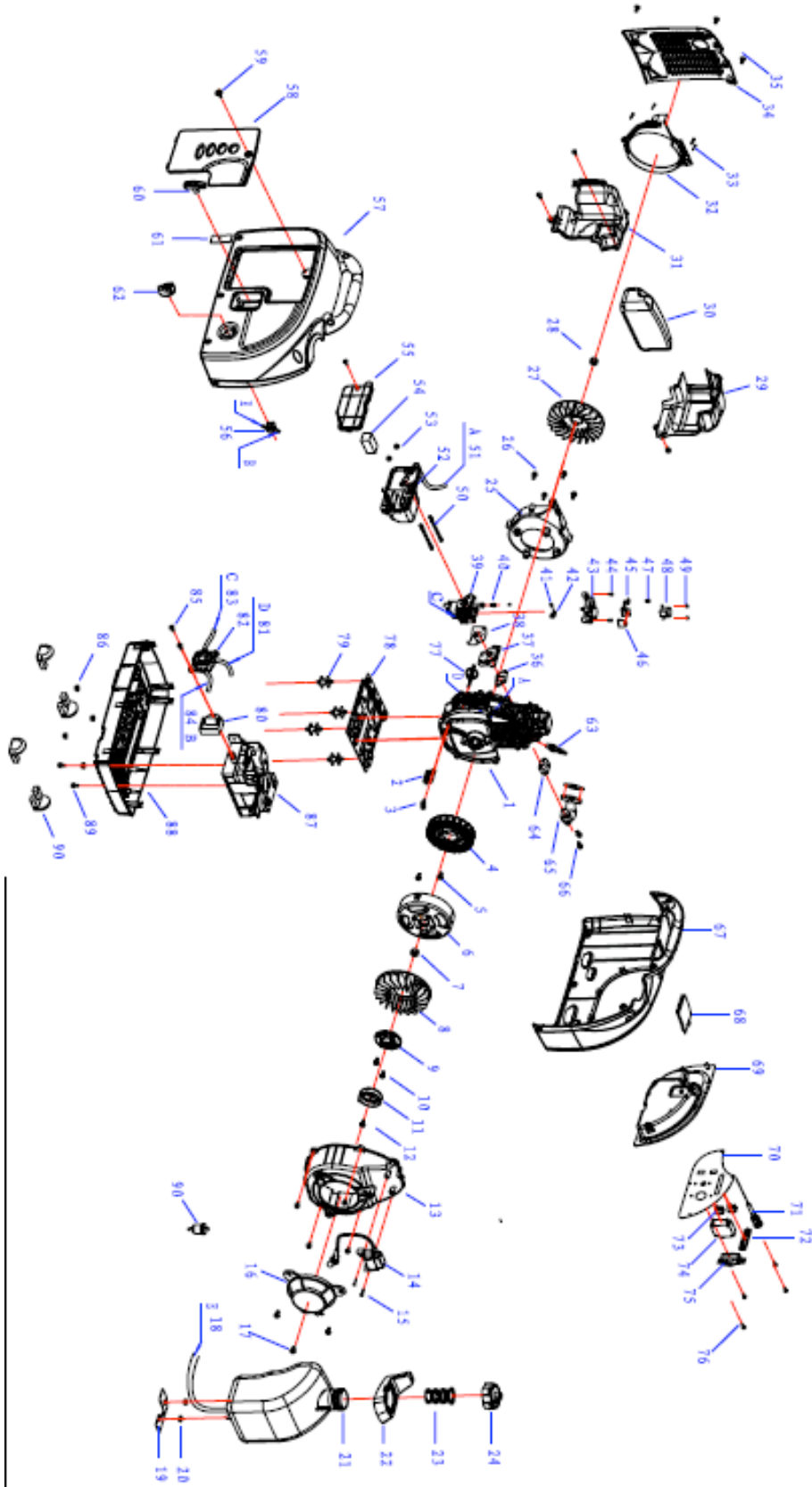

LIMITED WARRANTY

GOSS Power Products Ltd. ("GOSS") warrants as limited herein to the end-user original purchaser of the gasoline powered Generator to which this limited warranty, that the Generator shall be free of defects in material and workmanship for a period of (i) one year if purchased by a retail consumer for regular domestic usage; or (ii) 90 days if purchased for professional or industrial usage, in each case from the date of original purchase. In the event of malfunctions or failure of your Generator, simply deliver or send the Generator, along with proof of purchase, within the applicable warranty period to GOSS. GOSS reserves the right to inspect the claimed defective part or parts to determine if the defect or malfunction complaint is covered by this limited warranty. GOSS shall, within 60 days after receipt of the product, at its option, repair and/or replace the defective part or parts free of charge (other than delivery costs to transport the Generator or any part or parts thereof). This limited warranty shall only cover defects arising from normal usage, GOSS assumes no responsibilities whatsoever if the Generator should fail during the limited warranty period by reason of: (i) misuse, negligence, physical damage or accidents; (ii) lack of maintenance (see owner's manual for proper maintenance); (iii) repair by any unauthorized party during the limited warranty period. The limited warranty set out above is further qualified by the restrictions on usage and related matters as are set out in the owner's manual. Any contravention of the terms in the owner's manual shall render this limited warranty null and void and of no further effect.

GOSS makes no further warranties or representations, express or implied except those contained herein. No representative dealer is authorized to assume any other liability regarding the Generator. The duration of the implied limited warranty granted under any Provincial law, including warranties of merchantability and fitness for particular purpose are limited in duration to the express duration provided for herein. GOSS shall in no event be liable for direct, indirect, special or consequential damages. Should your Generator fail to operate under the terms of this limited warranty, please contact

GOSS Power Products Ltd.
6226 Danville Rd, Mississauga, ON, L5T 2H7
1-877-270-7772
www.gosspower.com



1-877-270-7772
6226 Danville Road
Mississauga, ON, L5T 2H7