



PARTS

CATALOGUE

GS4500W GS5500W

GOSS INDUSTRIES INC.

6226 Danville Road, Mississauga, Ontario L5T-2H7

Phone: 905-795-9830 x 226 fax: 905-795-9832

email: info@gossindustries.com

www.p3power.ca

FIG.A CYLINDER HEAD

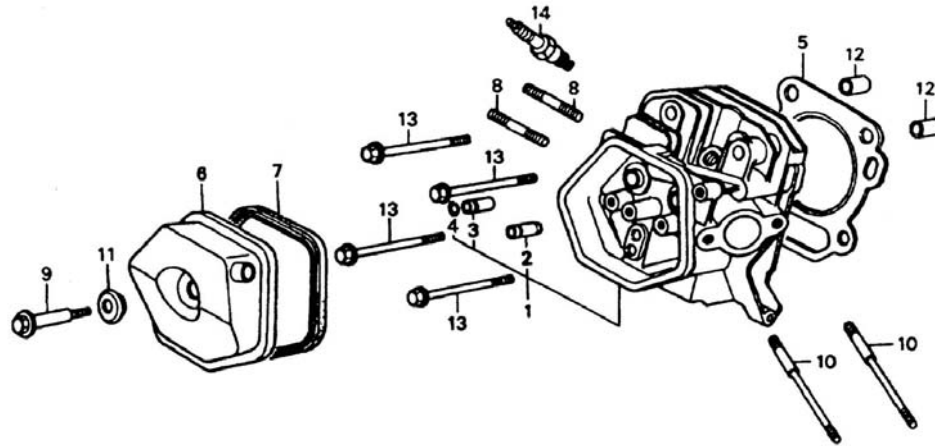

REF. NO.	DESCRIPTION	Q'TY
1	Cylinder Head	1
2	In valve guide	1
3	Ex valve guide	1
4	Valve guide clip	1
5	Cylinder head gasket	1
6	Head Cover,	1
7	Head Cover gasket	1
8	Bolt M8x48	2
9	Head Cover bolt	1
10	Bolt M8x130	2
11	Head Cover washer	1
12	Dowel pin	2
13	Bolt M10x80	4
14	Spark Plug	1

FIG.B CRANKCASE ASSY

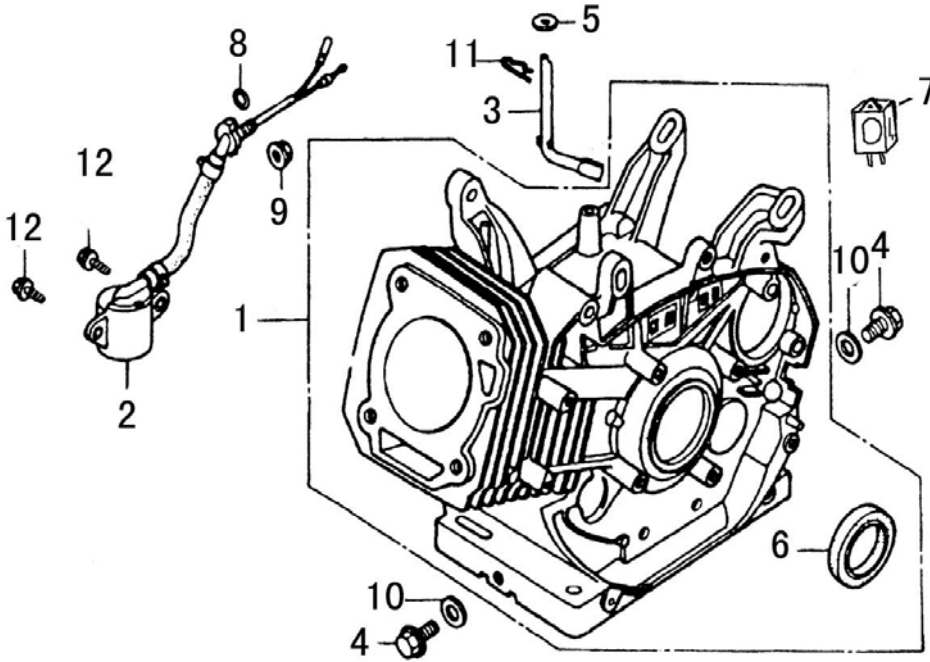

REF. NO.	DESCRIPTION	Q'TY
1	Crankcase assy	1
2	Oil sensor	1
3	Governor shaft	1
4	Drain bolt	2
5	Washer	1
6	Oil seal	1
7	Oil warning unit	1
8	O ring	1
9	Nut M10	1
10	Washer	2
11	Lock pin	1
12	Bolt M6×12	2

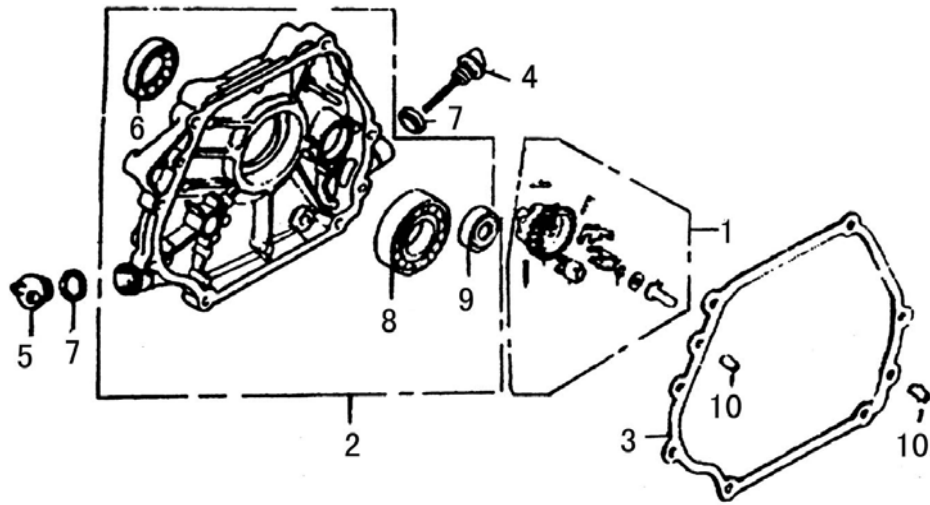

FIG.C CRANKCASE COVER

REF. NO.	DESCRIPTION	Q'TY
1	Governor kit	1
2	Crankcase cover assy	1
3	Case cover gasket	1
4	Oil level cap assy.	1
5	Oil cap	1
6	Oil seal	1
7	O ring	2
8	Bear (6207)	1
9	Bear (6202)	1
10	Dowel pin	2

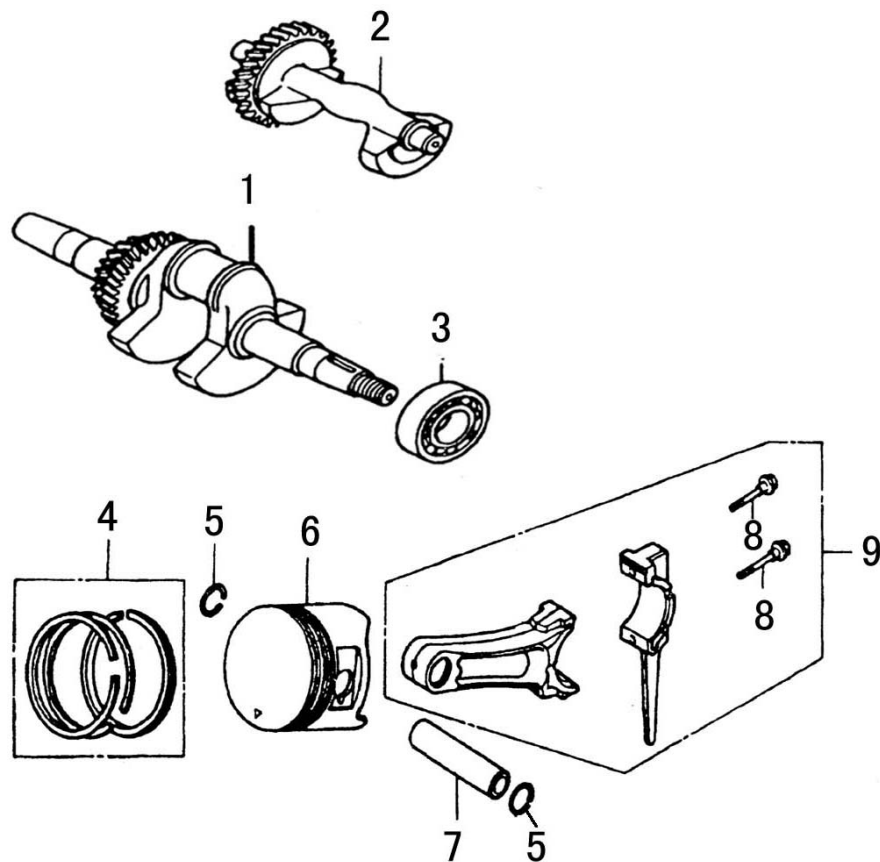
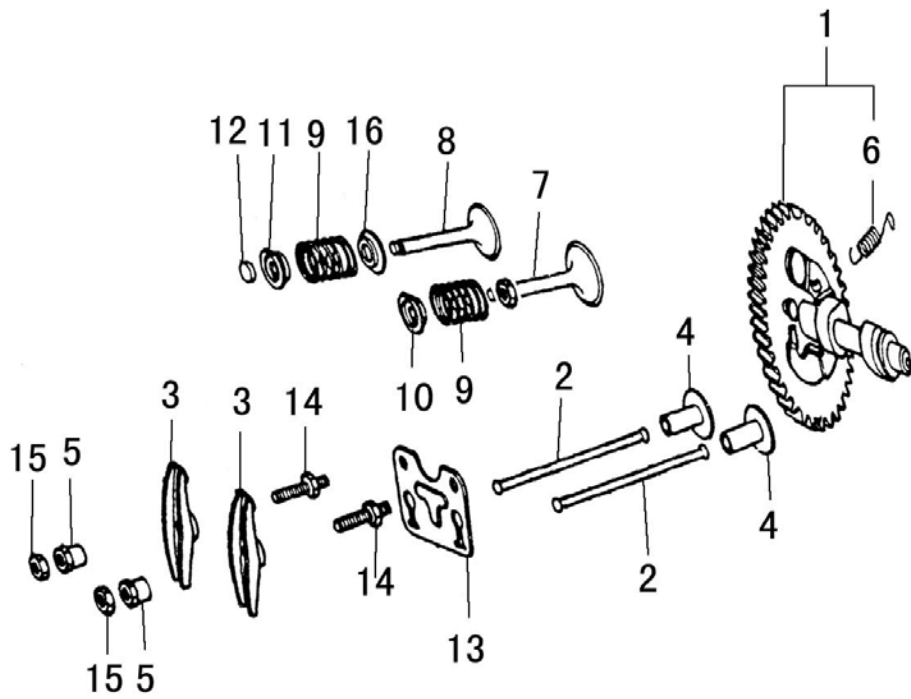

FIG.D CRANKSHAFT PISTON

REF. NO.	DESCRIPTION	Q'TY
1	Crankshaft assy(G-Type-Y)	1
2	Balancer weight	1
3	Bearing (6207)	1
4	Piston ring	1
5	Piston pin clip	2
6	Piston	1
7	Piston pin	1
8	Connecting rod bolt	2
9	Connecting rod	1



FIGE CAMSHAFT

REF. NO.	DESCRIPTION	Q'TY
1	Camshaft assy	1
2	Push rod	2
3	Valve rocker	2
4	Valve lifter	2
5	Rocker pivot	2
6	Weight return spring	1
7	Intake valve	1
8	Exhaust valve	1
9	Valve spring	2
10	Intake valve spring seat	1
11	Exhaust valve spring retainer	1
12	Valve rotator	1
13	Rocker seat	1
14	Adjusters screw	2
15	Adjusting nut	2
16	Exhaust valve spring seat	1

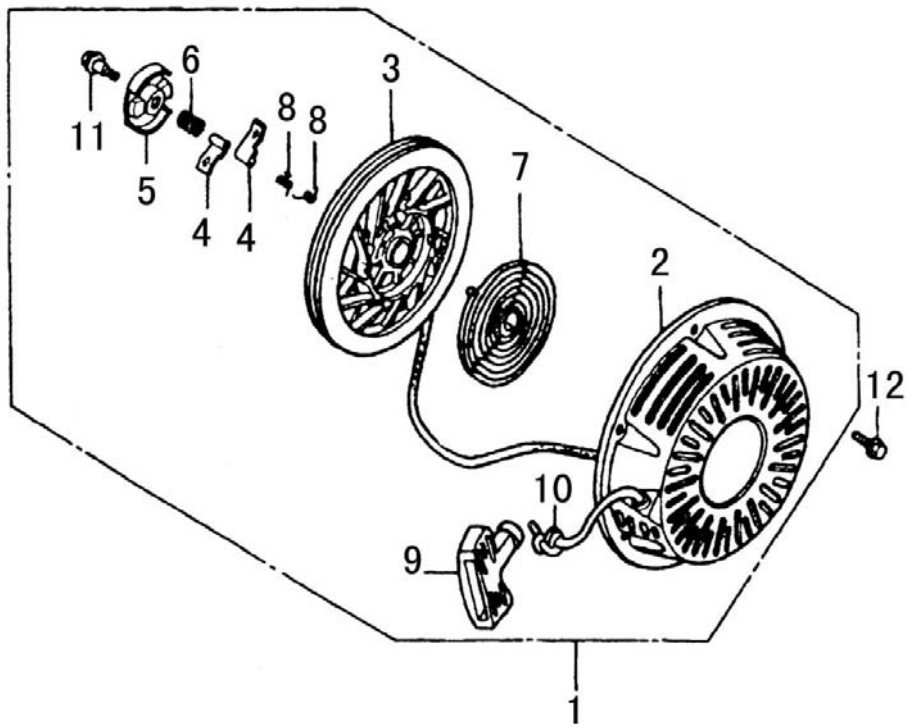

FIG.F RECOIL STARTER

REF. NO.	DESCRIPTION	Q'TY
1	Recoil starter	1
2	Recoil starter case	1
3	Drum sheave	1
4	Drive pawls	2
5	Drive pawls guide	1
6	Spring	1
7	Starter spring	1
8	Return spring	2
9	Handle	1
10	Recoil starter rope	1
11	Screw	1
12	Flange bolt M6x8	3

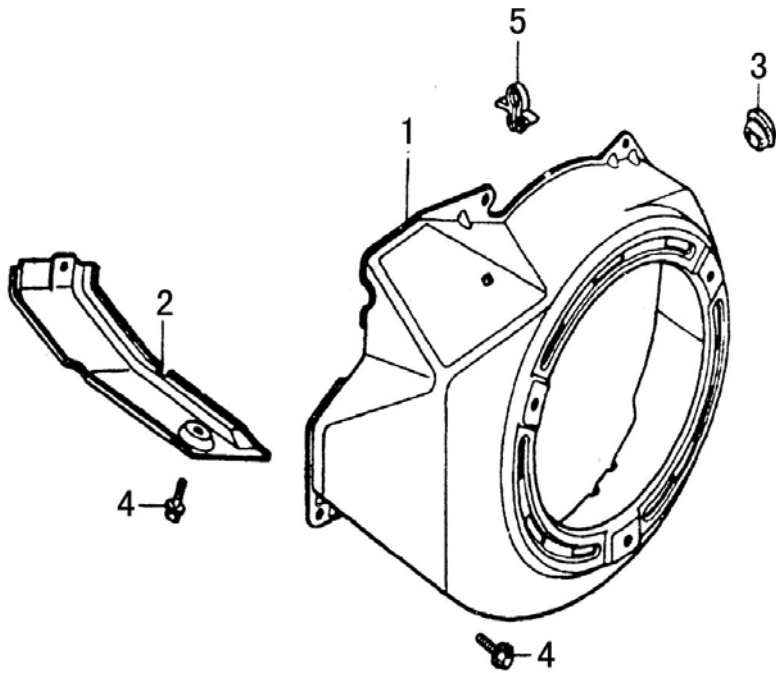

FIG.G FLYWHEELCOVER

REF. NO.	DESCRIPTION	Q'TY
1	Flywheel cover	1
2	Air shroud	1
3	Drain hole grommet	1
4	Bolt M6×12	6
5	Wire clip	1

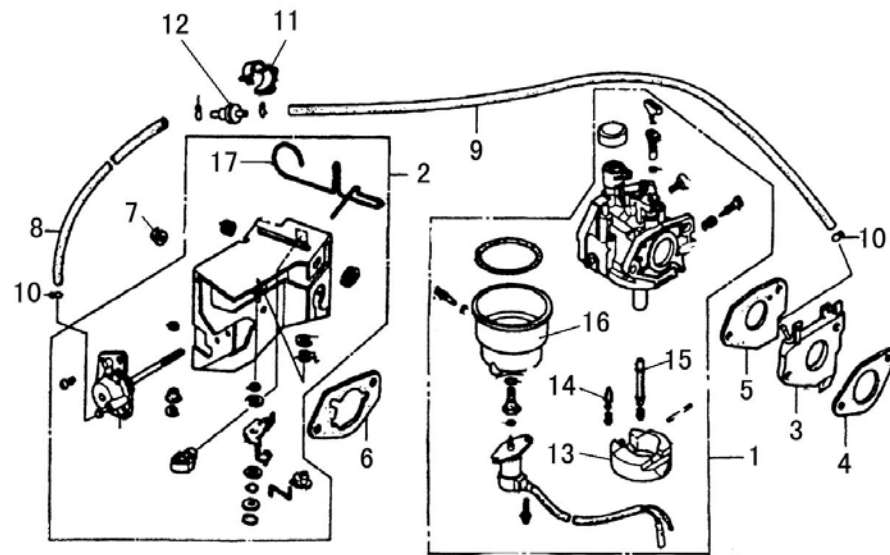

FIG.H CARBURETOR

REF. NO.	DESCRIPTION	Q'TY
1	Carburetor	1
2	Manual choke assy	1
3	Carburetor insulator	1
4	Carburetor packing A	1
5	Carburetor packing B	1
6	Air cleaner packing	2
7	Nut M5	2
8	Tube	1
9	Tube	1
10	Clip	4
11	Wire clip	1
12	Dashpot check valve	1
13	Float	1
14	Needle assembly	1
15	Main nozzle	1
16	Float chamber body	1
17	Choke lever	1

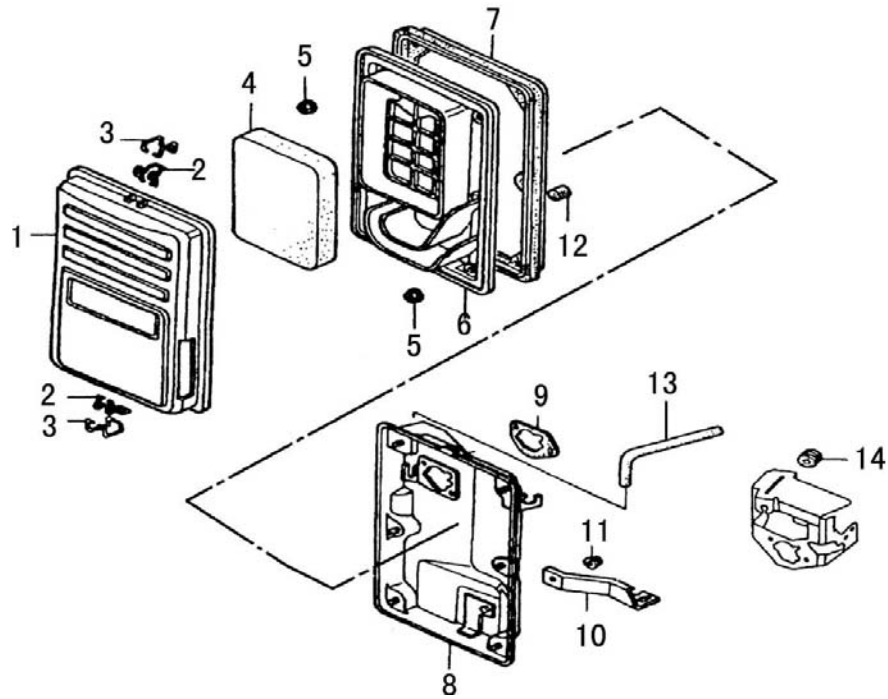

FIG.I AIR CLEANER

REF. NO.	DESCRIPTION	Q'TY
1	Air cleaner cover	2
2	Air clean clip A	2
3	Air clean clip B	2
4	Element	1
5	Nut M5	6
6	Air cleaner separator	1
7	Air cleaner seal	1
8	Air cleaner case	1
9	Gasket	1
10	Air cleaner holder	1
11	Bolt M6	1
12	Filter drain tube	1
13	Recoil pipe	1
14	Grommet	1

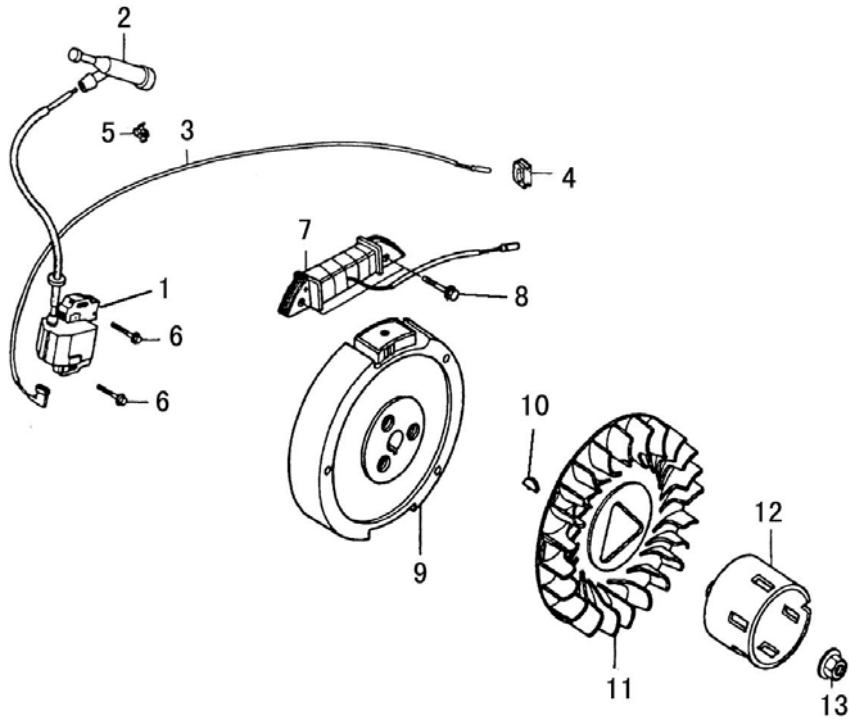

FIG.J FLYWHEEL

REF. NO.	DESCRIPTION	Q'TY
1	Ignition coil assy.	1
2	Spark plug cap	1
3	Stop switch cord	1
4	Cord grommet	1
5	Stop switch holder	1
6	Bolt M6×28	2
7	Charge coil	1
8	Bolt M6×28	1
9	Flywheel	1
10	Semicircle key	1
11	Fan	1
12	Starter pulley	1
13	Nut M16	1

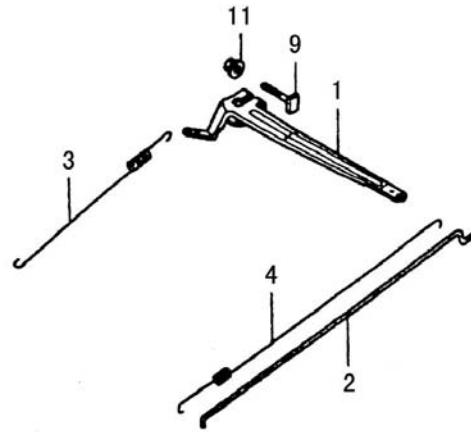
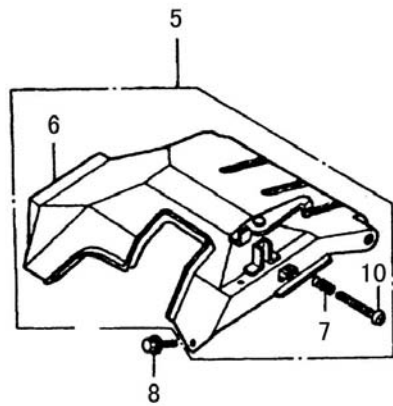

FIG.K GOVERNOR

REF. NO.	DESCRIPTION	Q'TY
1	Governor arm	1
2	Link rod	1
3	Governor spring	1
4	Spring	1
5	Control assy	1
6	Governor	1
7	Governor adjusting spring	1
8	Bolt M6×12	3
9	Bolt M6×12	1
10	Screw M5×35	1
11	Nut M6	1

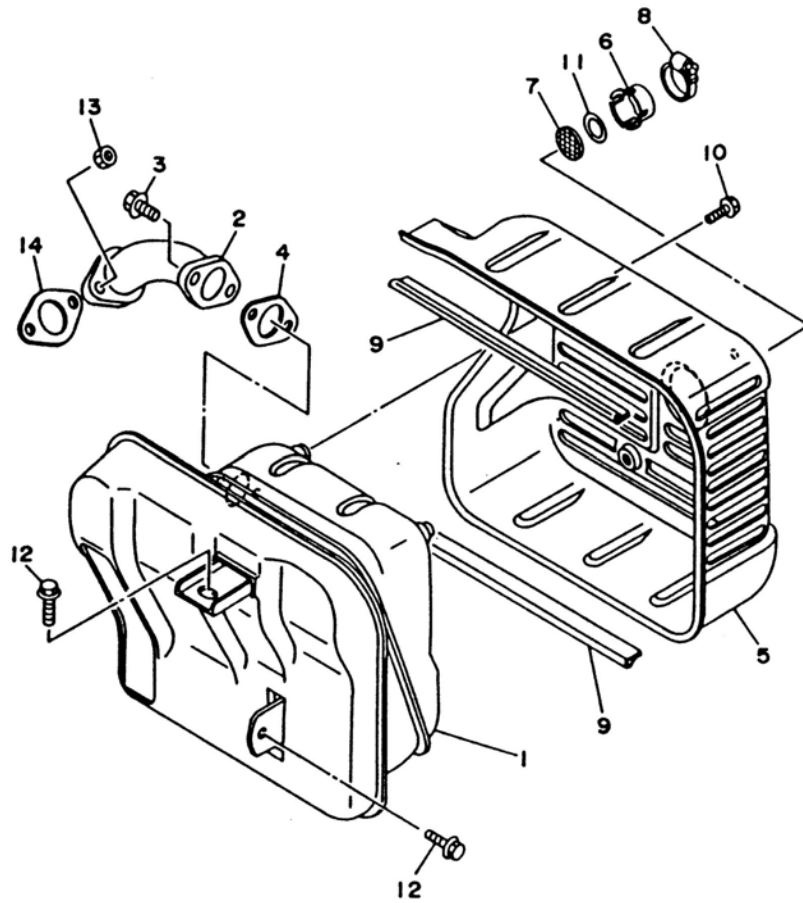
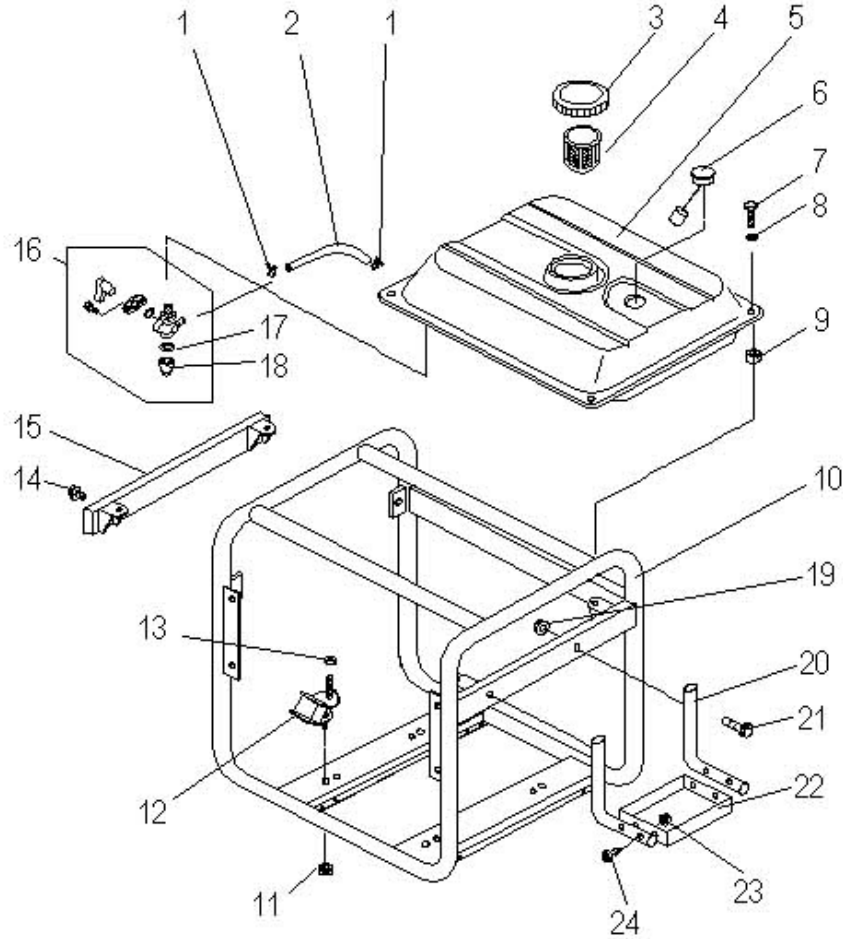

FIG.1 MUFFLER

REF. NO.	DESCRIPTION	Q'TY
1	Muffler	1
2	Exhaust pipe HM-5	1
3	Bolt	2
4	Exhaust pipe gasket	1
5	Protector assy	1
6	Exhaust cover	1
7	Net	1
8	Clasp	1
9	Muffler protector seal	2
10	Bolt	4
11	Washer	1
12	Bolt	2
13	Nut	2
14	Exhaust pipe gasket	1

FIG.M FUEL TANK FRAME



REF. NO.	DESCRIPTION	Q'TY
1	Clip	2
2	Fuel hose	1
3	Fuel cap	1
4	Fuel filter	1
5	Fuel tank	1
6	Fuel level gauge	1
7	Bolt	4
8	Washer	4
9	Rubber	4
10	Frame assy	1
11	Nut	4
12	Vibration absorber	4
13	Nut	4
14	Bolt	2
15	Holder	1
16	Fuel cock	1
17	Strainer	1
18	Fuel petcock cup	1
19	Nut M6	2
20	Battery kit	2
21	Bolt M6x40	2
22	Battery box	1
23	Nut M6	4
24	Bolt M6x35	4

FIG O. GENERATOR

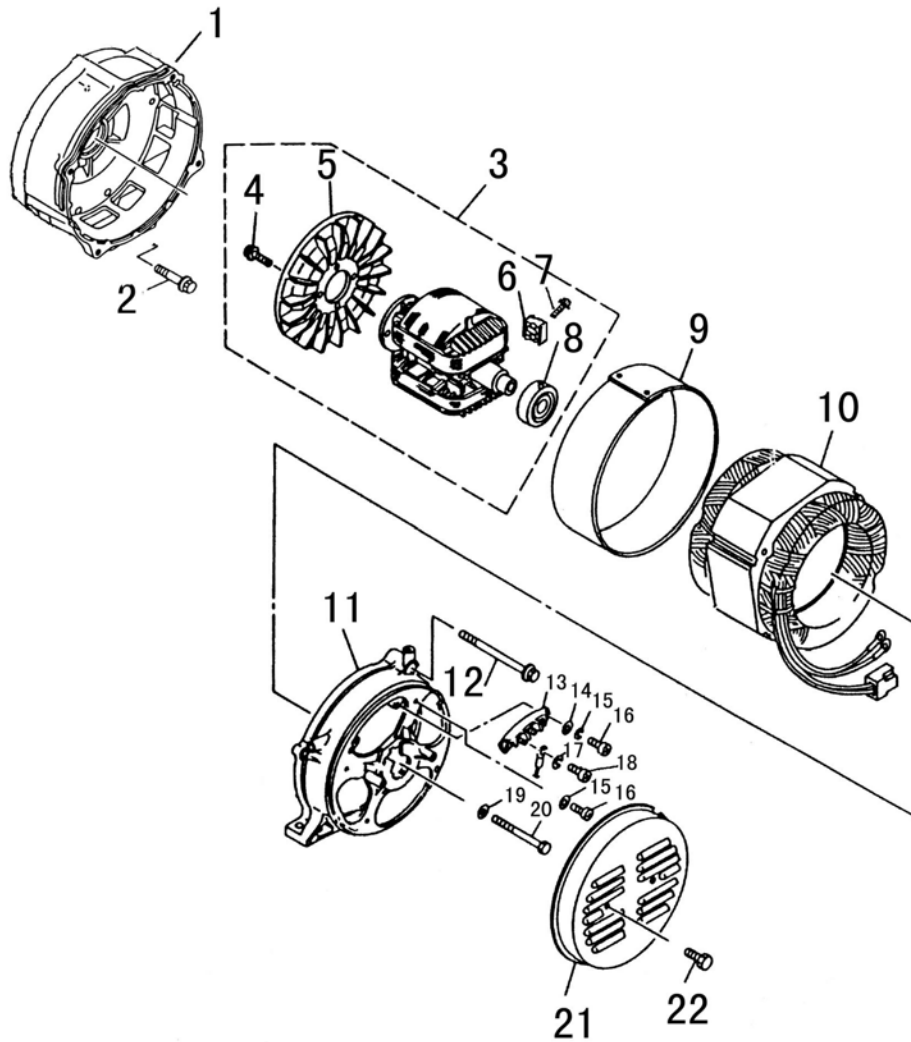

REF. NO.	PART NAME	Q'TY
1	Front Cover	1
2	Flange Bolt M8x30	4
3	Rotor Assy	1
4	Bolt M6x16	4
5	Fan blade	1
6	Rectifier	1
7	Bolt M5x20	1
8	Bearing 6305	1
9	Stator cover	1
10	Stator Assy	1
11	Rear Cover	1
12	Flange Bolt M8x105	4
13	Plate	1
14	Washer	2
15	Washer	2
16	Bolt M6x16	2
17	Washer (copper)	8
18	Bolt M6x16(copper)	4
19	Washer	1
20	Bolt M10x230x1.25	1
21	End Cover	1
22	Bolt M6x10	2

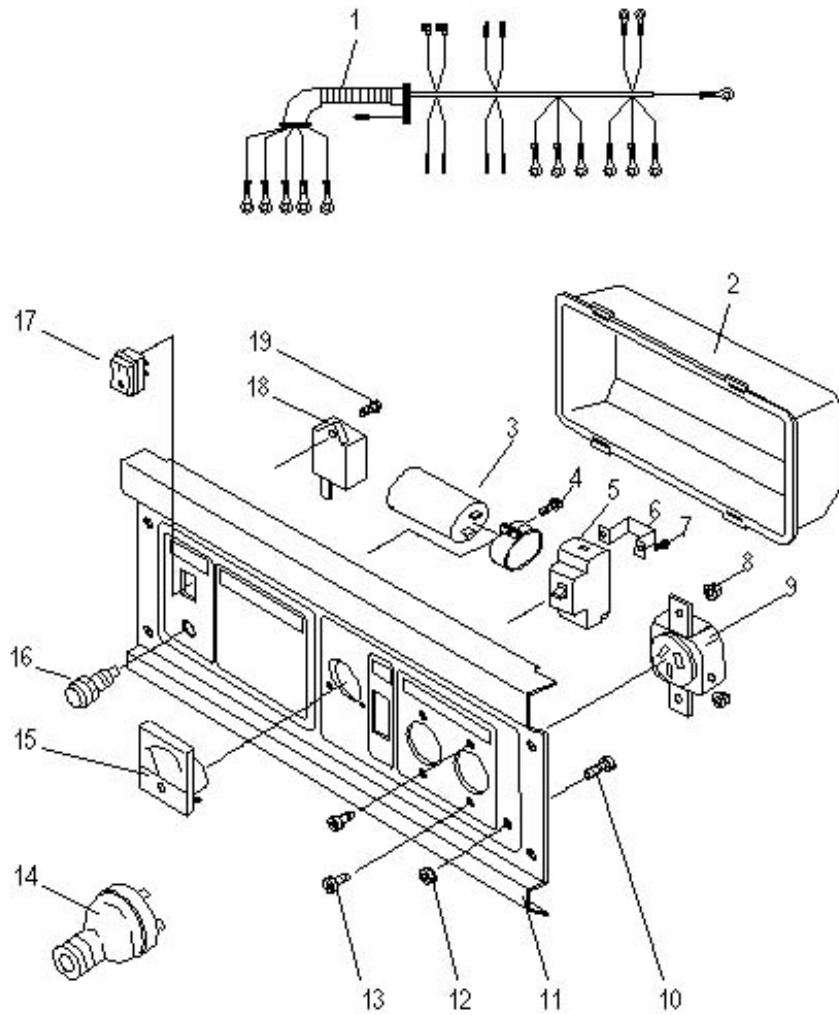

FIG P. CONTROL PANEL

REF. NO.	PART NAME	Q'TY
1	Wiring harness assy.	1
2	Back cover	1
3	Capacitor 20uf/450V	1
4	Screw M5×12	1
5	AC circuit breaker	1
6	Clasp	1
7	Screw M4×10	2
8	AC socket	2
9	Nut M4	4
10	Bolt M6×20 (copper)	1
11	Control panel	1
12	Nut M6 (copper)	2
13	Screw M4×10	4
14	AC plug	2
15	Voltmeter	1
16	Oil warning light	1
17	Engine switch	1
18	Oil warning unit	1
19	Screw M5×20	1