

P3-POWER™

GSE5230STG

Engine Manual

Guide de Utilisateur Moteur



IMPORTANT: BEFORE OPERATING ENGINE – AVANT D'UTILISER LA POMPE À EAU

Failure to follow instructions may result in serious injury or death

Une mauvaise utilisation de l'appareil pourrait causer des blessures graves et entraîner la mort.

CONTENTS

Notice

1. General Information
2. Components & Principle
3. Safety Instruction
4. Specifications
5. Operation
6. Trouble Shooting
7. Maintenance & Servicing
8. Storage & Transportation

Notice

Read this manual carefully before operation.

All rights reserved. Copy or transcribing this manual or any part of this manual is strictly prohibited without written authorization.

Please pay attention to the following safety labels that indicates personal safety is required.



: WARNING indicates death, personal injury and/or property damage may occur if instructions are not followed carefully



: CAUTION indicates personal injury and/or property damage might occur if instructions are not followed carefully.

This manual is a part of the engine and should be transferred with the engine if the proprietorship is changed.

1. General Information

This manual applies to 178/183/190 series engines. Please read this manual carefully prior to operating the engine.

The engine is single cylinder, 4-stroke, forced cooling, OHV engine with transistor ignition and oil alarm system. It was carefully engineered to provide excellent performance when properly operated and maintained. The service/repair network will help you solve any potential problem upon your request.

The figures in this manual are for operation reference only and they may not be exactly same as the productions. The manual shall be subjected to any changes due to continuous improvement and/or generation changes without additional notices.



Please be sure that you, and any other persons who will operate the engine, carefully follow the recommended safety practices at all times. Failure to do so could result in personal injury or property damage.

2. Components & Principle

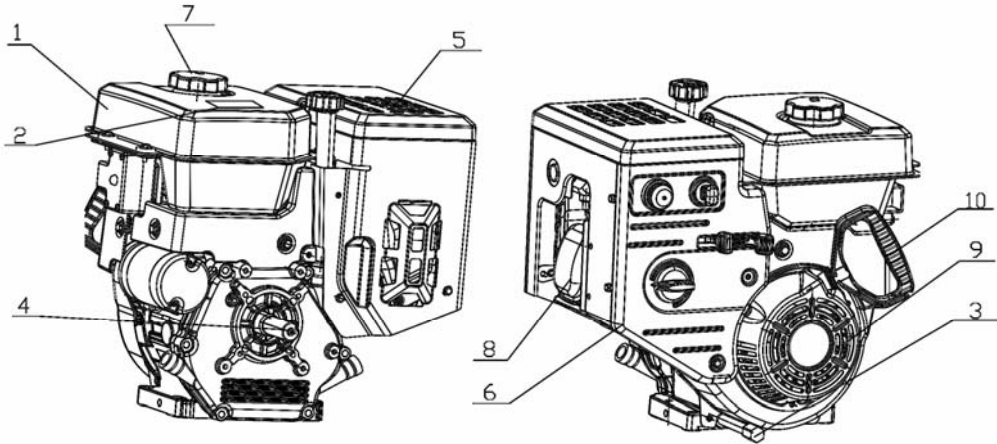

1. Fuel tank 2. Safety label 3. Drain bolt 4. output shaft 5. Muffler guard

6. Control panel 7. Fuel gap 8. Cylinder head cover 9. Starter 10. Starter handle

3. Safety Instruction



- The engine shall be operated only by qualified person.
- Exhaust gases contain carbon monoxide, an odorless and deadly poison. Do not use indoors
- For personal safety, please pay attention to the following labels:
- DO NOT touch muffler, cylinder or other hot parts which may cause burns.
- Keeps engine always from kids.
- To reduce fire hazards, keep machine free of grass, leaves, or other debris build-up. Clean up oil or fuel spillage and remove any fuel soaked debris.
- Never fuel machine indoors

- Never remove gas cap or add fuel or oil while the engine is hot or running. Allow engine to cool at least two minutes before refueling.
- Never over fill fuel tank. If gasoline is spilled, wipe it off the engine.
- Always check oil level prior to operation. Do not operate the engine without enough oil.



Long-time and repeated contact with gasoline or fuel vapor may cause skin cancer. Wash hands with soap as soon as possible after that. And keep machine away from kids



For the purpose of environment protection, we advise you put the used oil into a sealed container, and send it to the local service or recycle station.
Never dump the oil on soil or sewage systems.

4. Specifications

GSE5230STG	
Model	190
Bore(mm) x Stroke(mm)	90 x 66
Displacement (cm ³)	419
Compression Ratio	8.0 : 1
Fuel Consumption Rate (g/kW/h)	≤370
Oil Consumption Rate (g/kW/h)	≥6.8
Idle Speed (rpm)	1440 + 144
Valve Lash (mm)	IN: 0.10 ~ 0.15. EXH: 0.15 ~ 0.20
Noise Limit	Conformance with GB15739-1995
	Test Standard: GB/T1859-2000
Max. Power/Speed (kW/rpm)	7.8/3600
Max. Torque/Speed (NM)	23/2750
Ignition System	Transistor
Starter	Recoil and electric

5. Operation

1. Before Operation



No fuel or oil in engine. Fill fuel and oil before using.

1.1 Check oil level.

- a. Remove dipstick and clean it.
- b. Insert the dipstick into oil filler neck as shown in figure 5-1, but do not screw it in, then remove it out and check oil level.
- c. Fill with the recommended oil to the upper limit if necessary. Do not overfill.
- d. Reinstall dipstick.



Oil is a major factor affecting performance and service life. 4-stroke automotive detergent oil SAE 5W-30 is recommended for this wintertime engine.

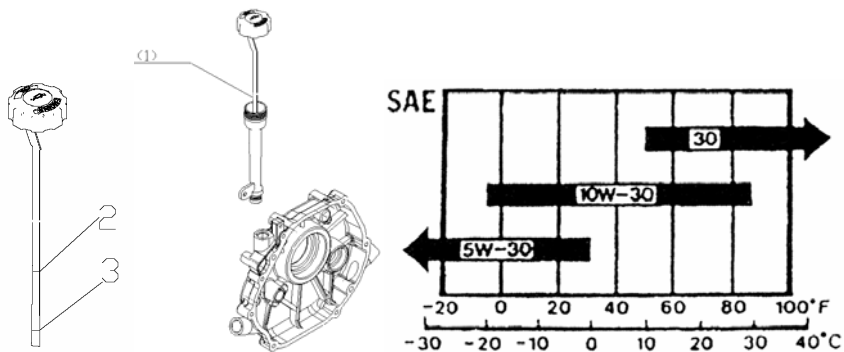

Figure 5-1

- 1 – Dipstick
- 2 – Upper limit
- 3 – Lower limit

1.2 Check fuel level.

a. Remove the fuel cap.

b. Add unleaded gasoline to the bottom of the fuel level limit (A red plate in the neck of the fuel tank).

c. Wipe up spilled fuel and reinstall the cap.

1. Fuel tank
2. Fuel neck
3. Fuel limit

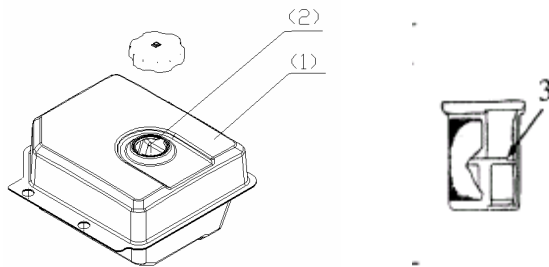

Figure 5-2



Gasoline is highly flammable and explosive, you can be burned or seriously injured during refueling.

Stop engine and keep heat, sparks, and flame away.

Refuel only outdoors.

Gasoline is poisonous, be careful not to touch it or inbreathe its vapor.

2. Starting Engine

2.1 Press the primer three times for an interval of 1 second.

1 - primer

Figure 5-3



2.2 Put choke lever to a suitable position

2.3 Move throttle control lever to a suitable position

2.4 Pull starter handle lightly until you feel resistance, then pull briskly.

2.5 After engine warm up, open the choke gradually.

2.6 Let engine run a few minutes at idle speed to warm up before operating.

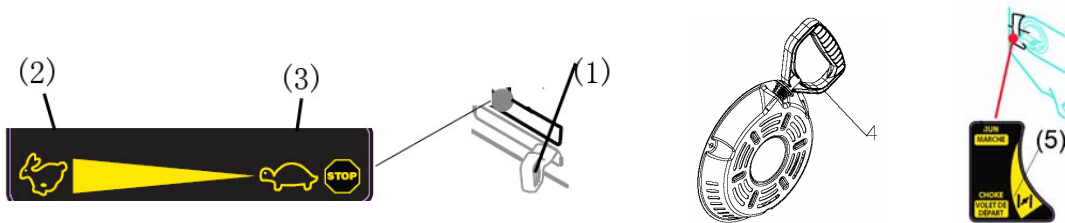

1 - throttle control lever 2 - throttle "open" 3 - throttle "close"

4 - starter 5 - choke "close"

Figure 5-4

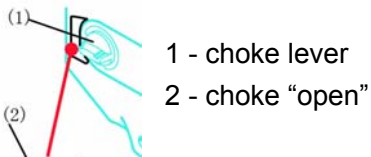

1 - choke lever

2 - choke "open"

Figure 5-5



Do not use choke if engine is warm or the ambient temperature is very high.
Do not allow the starter grip to snap back against the engine. Return it gently.

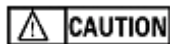

For your health, do not face to exhaust outlet while engine is running.

3. Stop Engine/After Use



IN AN EMERGENCY

Move throttle control lever to “close” position or draw out engine switch immediately.



1 - engine switch

Figure 5-6

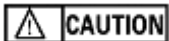

Do not stop engine with load in normal condition.

4. Adjustment

Each adjustable part is set at right range and no more adjustment is needed.

You can reset it as following instruction if necessary:

4.1 Valve lash adjustment

Intake: 0.10—0.15mm; Exhaust: 0.15—0.20mm.

- a. Grasp adjust nut and release lock nut.
- b. Turn adjust nut to specified lash.
- c. Grasp adjust nut and screw down lock nut (torque: 9-12N.m).
- d. After screw down lock bolt, recheck valve gap.

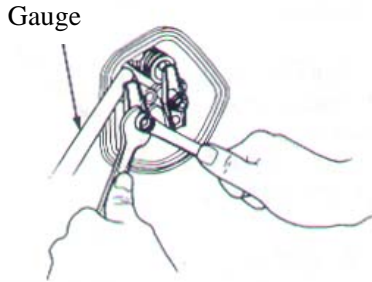

Fig 7-6

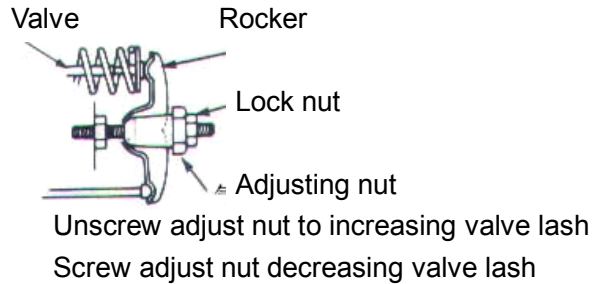

Fig 7-7

4.1 Governor system adjustment (tension spring, governor lever and bracket)

- Remove fuel tank.
- Unscrew lock nut and then move bracket to place throttle at wide open position.
- Turn governor lever in the same direction as above step. Screw lock nut after governor lever turn to farthest position.
- Check to see if bracket and valve move smoothly.
- Reinstall fuel tank.

6. Trouble Shooting

1. Difficult to start

Problem	Cause		Solution
No spark/ignition	Spark plug	Deposit existing Spark plug gap issue Insulation damaged	Clean or replace Adjust to 0.7 ~0.8mm Replace
	Other parts	Damaged Ignition module Flywheel magnetic issue	Replace Ignition module Replace flywheel
Having spark/ignition	Good compressing	Fuel flooded Having water or dirt with fuel	Dry spark plug Change fuel
	No fuel comes out after unscrew drain bolt	Blocked needle vale	Clean or replace
	Not good compressing	Worn/torn piston ring Loosed spark plug Timing or valve lash issue Leak from combustion chamber	Replace Re-tight Readjust Replace gasket

2. Unconventional running

Problem	Cause	Solution
Low speed/lack of power	Chock not open High back pressure at muffler Worn/torn moving parts Governor system setting issue Poor ignition Valve lash issue Deposition in combustion chamber	Open choke Replace muffler Check/replace Adjust Replace ignition module or flywheel Adjust Clean
Hunting	Governor system setting issue Carburetor issue Spark plug gap issue	Adjust Check/clean/replace Adjust
High speed	Governor system setting issue	Adjust
Noise	Valve lash setting issue Damaged camshaft	Adjust Replace
Fuel leak	Needle valve issue	Clean/replace
	Distorted O-ring	Replace

7. Maintenance & Servicing

Scheduled maintenance will guarantee your engine performance in its life. Check following table for detailed information.

Scheduled maintenance list

Regular service period	Before each use	Monthly or every 25Hrs	Every 3 months or 50Hrs	Every 6 months or 100Hrs	Annually or every 300Hrs
Engine oil	Check	Replace		Replace	
Air filter	Check		Replace		
Fuel filter				Clean	
Spark plug				Clean/adjust	
Fuel tank					Clean

8. Storage & Transportation



Allow engine to cool before transportation or storage.

Fasten engine during transportation to reduce the possibility of fuel leak.

When the engine will not be use for long time, prepare it for storage with the following steps.

1. Empty fuel tank.
2. Start the engine and let it run until it stops due to lack of fuel.
3. Change engine oil if it will be stored longer than 3 months.
4. Remove the spark plug and empty a little engine oil (about 30 ml) in the hole. Crank the engine a couple of times. Reinstall spark plug.
5. Clean the whole engine thoroughly.
6. Lubricate all the parts outside if necessary.
7. Inspect engine for damage and repair it if necessary.
8. Rust protection to the metal surfaces.
9. Store the machine indoors if possible.



1-877-270-7772
6226 Danville Road
Mississauga, ON, L5T 2H7